

Service
Service
Service



Service Manual



Contents	Page
1 Technical Specification and Connection Facilities	1-1 to 1-9
2 Laser Beam Safety Precautions.....	2-1
3 Important Safety Precautions	3-1 to 3-2
4 Safety Check After Servicing	4-1
5 Safety Information General Notes & Lead Free Requirements	5-1
6 Standard Notes For Servicing,Lead Free Requirements & Handling Flat Pack IC	6-1 to 6-4
7 Direction of Use	7-1 to 7-3
8 Cabinet Disassembly Instructions	8-1 to 8-2
9 Troubleshooting	9-1 to 9-2
10 Block Diagram	10-1
11 Wiring Diagram	11-1
12 AMP Board	
Circuit Diagram	12-1
Layout Diagram	12-2
13 Display Board	
Circuit Diagram	12-3
Layout Diagram	12-4

Contents	Page
14 Headphone & MP3 Link and USB- LED Board	
Circuit Diagram	12-5
Layout Diagram.....	12-5
15 Key Board	
Circuit Diagram	12-6
Layout Diagram	12-7
16 Power Board	
Circuit Diagram	12-8 to 12-9
Layout Diagram	12-10
17 Decoder Board	
Circuit Diagram	12-11 to 12-13
Layout Diagram	12-14
18 Exploded View.....	13-1
19 Revision List	14-1

©Copyright 2011 Philips Consumer Electronics B.V. Eindhoven, The Netherlands.
All rights reserved. No part of this publication may be reproduced, stored in a retrieval system or transmitted, in any form or by any means, electronic, mechanical, photocopying, or otherwise without the prior permission of Philips.

Feature	Feature Different	/12
RDS		✓
Voltage Selector		
ECO Standby		✓
DTS		



Technical Specification and Connection Facilities

Location of PC Boards

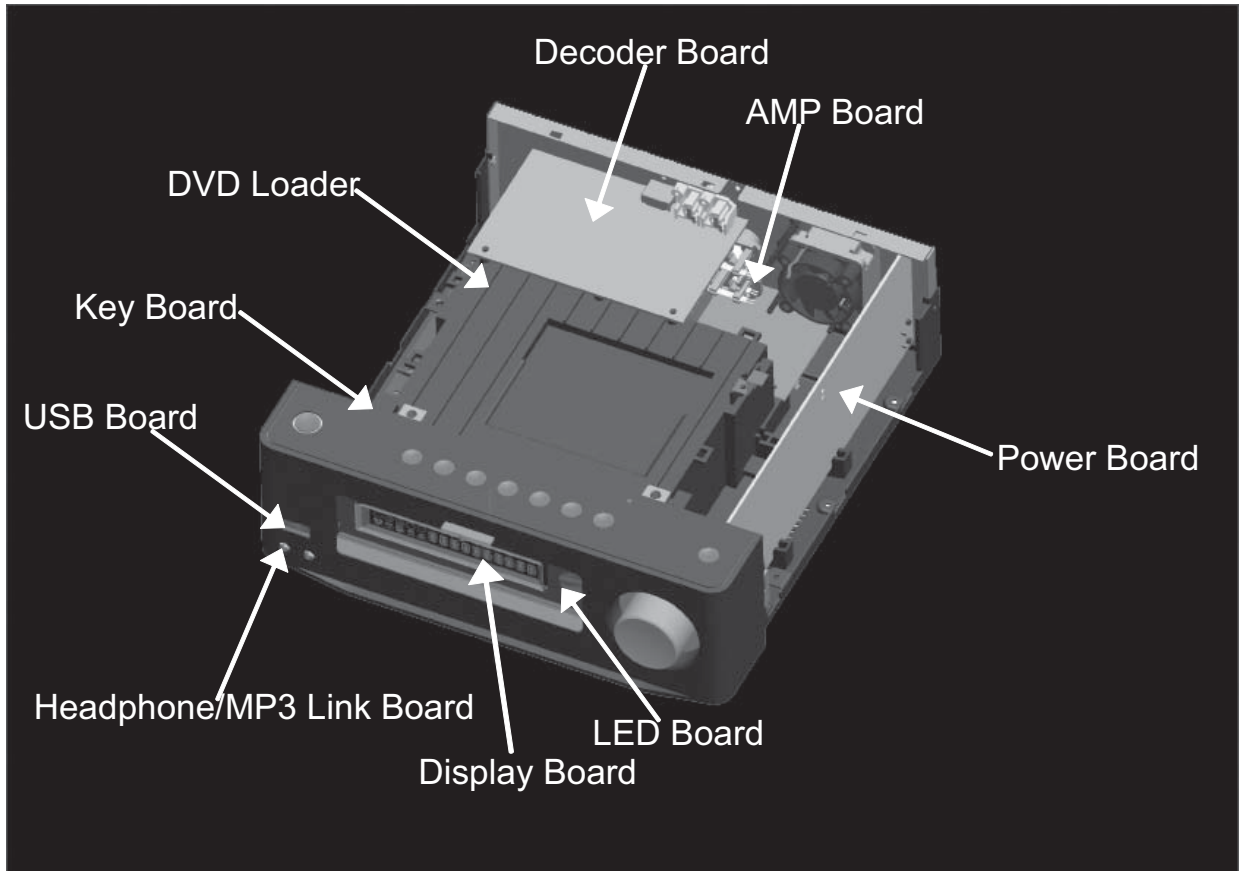

Version Variations

Type /Versions:		MCM7000										
Board in used:	Service policy	/05	/12	/51	/55	/58	/61	/79	/93	/94	/96	/98
LED Board			C									
Decoder Board			M									
Display Board			C									
AMP Board			C									
Headphone & MP3 Link Board			C									
Power Board			M									
USB Board			C									
Key Board			C									
Type /Versions		MCM7000										
Features	Feature difference	/05	/12	/37	/55	/58	/61	/79	/93	/94	/96	/98
RDS			√									
VOLTAGE SELECTOR												
ECO STANDBY - DARK			√									
DTS												
* TIPS : C -- Component Lever Repair M -- Module Lever Repair √ -- Used												

Technical Specification and Connection Facilities

Technical Specification

1. General Information and Requirement

1.1 Product Family Features

1.1.1 Identity and Key Features

MCM7000 series are Heritage Range Micro Audio System CD/MP3 player with USB and Tuner FM(20presets)

Elements to include as generic requirements:

1. Detachable mains cord
2. Safety certification (cUL/FCC and CB/EMC/CE)

Following is a list of key features:

1. USB true source
 - a) MSC & MTP
 - b) USB High Speed
2. iPod/iPhone docking – Integrated, support iPad
3. MP3 Link (via headphones jack from PC or MP3 player)
4. Headphone Out (Front of the set TBC)
5. Tuner FM
6. Total output power 2x30Wrms

2.1.2 Styling, Forms and Functions

MCM7000 appearances are defined in their respective MUS. MUS is the leading document where product appearance is applicable..

Features	Products	MCM7000
	Stroke versions	All
	Design	Refer to MUS[3] for details
Front	Optical Drive Loading	Tray
	Tray Location	below
	Tray Orientation	HORIZONTAL
	VFD	UP
Dimension	Height of feet	3mm
	Main Unit Speaker Box W x D x H (mm)	250X92X285mm 174X260X240mm
Weight	With packaging	10kg
Cosmetics	Color	Silver
	Buttons	Silver

Technical Specification and Connection Facilities

2.1.3 External I/O Connections

Model	MCM7000
Stroke Version	All
USB	√
MP3 Link (3.5mm audio jack)	√
Aux In (RCA cinch)	√
Tuner Socket (for FM)	√
Headphone Out (3.5mm audio jack)	√

2.1.4 Controls, Local Display and LED Indications(tbc)

Control keys on the set are:

Model	MCM7000
Standby	√
Source(Disc/USB/FM/Aux/MP3_link)	√
Eject	√
Play/Pause	√
Volume Rotator	√
DSC	N
DBB	N
Treble Rotator	N
Bass Rotator	N

There is local display VFD. Standby LED colour: Blue in Standby mode

Technical Specification and Connection Facilities

2.1.5. ACCESSORIES (tbc)

Model	MCM7000
Stroke Version	12
Region	Europe
Power Cord	1.8M
AV cable	1.5M
Audio cable (3.5mm audio)	0.5M
Tuner Antenna	1.5M 75ohm
Speaker cable	3M
USB cable	NA
Remote Control	44keys
Battery	AAAx2
Quickly guide	1
IFU	1

3.Mechanical General Information

The product appearances and functions are defined in their respective MUS.Product management approves the MUS and it is a leading document where product appearance is applicable.

Please refer to Sh560 for mechanical information.

3.1.Safety Standards

Where applicable:

For /12 (EU), /05 (UK), /51 (Russia)

For /37 (US, Canada)

For /55 (LATAM), /78 (Brazil)

For /98 (AP), /69 (Singapore), /75 (Australia)

For /93 (China)

For /61 (Korea)

For /96 (Taiwan)

EN/IEC 60065 7th Edition

UL 60065

IEC 60065 7th Edition

IEC 60065 7th Edition

GB 8898 (IEC 60065 7th Edition)

K 60065 6th Edition

CNS 14408 (IEC 60065 7th Edition)

3.2.EMC Requirements

Where applicable:

For /12 (EU), /05 (UK), /51 (Russia)

For /37 (US, Canada)

For /55 (LATAM), /78 (Brazil)

For /98 (AP), /69 (Singapore), /75 (Australia)

For /61 (Korea)

For /93 (China)

For /96 (Taiwan)

EN55013: 2001, EN55020: 2002

FCC15

CISPR13

CISPR13

CISPR13/20

GB 13837 (CISPR13)

CNS 13439 (CISPR13)

Technical Specification and Connection Facilities

3.3.ESD Requirements

The product shall withstand electro static discharges on all user accessible parts of the product.
Reference: IEC61000-4-2.

For contact discharges:

Level	General(kV)	USA(kV)	Requirement
1	0-2	0-3	No deviations allowed.
2	>2-4	>3-4	Short perceptible deviations allowed
3	>4-5	>4-5	Normal recallable functions function changes allowed.
4	>5-7	>5-7	Control recallable functions function changes allowed.
5	-	>7-8	No loss of stored data allowed.

For air discharge:

Level	General(kV)	USA(kV)	Requirement
1	0-4	0-6	No deviations allowed.
2	>4-8	>6-8	Short perceptible deviations allowed
3	>8-10	>8-10	Normal recallable functions function changes allowed.
4	>10-15	>10-15	Control recallable functions function changes allowed.
5	-	>15-18	No loss of stored data allowed.

General requirement:

1. 10 arcs for positive and negative polarity for unit "on" and "off" for 1kV incremental steps.
2. Component or mechanical damage is not allowed. No loss of fixed stored data (stored in EEPROMs).
3. Hang-ups and malfunctions are allowed, as long as the customer can "recover" from the hang-up by pressing the Standby or ON/OFF button of the set.
4. Failures that disappear only by unplugging the AC mains cord and/or power sources are not acceptable.

3.4.Environmental Condition

The environmental condition requirements and test method is according to UAN-D1590.

Ambient temperature : max. 40 °C - all climates

Apparatus acc. to spec. : +5 to + 35°C

Vibration test (acc. IEC 60 068/2/6) : operational vibration test to be proceeded in operating position of the set.

3.5.Quality

PQR-class: class 2 according to BLC A&MA PQR handbook V2.1 (2006-10-02)

Lifetime: 7 years

Tested According to: General Test Instruction UAN-D 1591

Measured According to: UAN_L 1059 unless otherwise stated

Technical Specification and Connection Facilities

4. Technical Specifications

Power Supply

4.1.1 Type and versions

Build-inSMPS will be used for all models and stroke versions.

All using figure '8' socket, will cater for all versions:

Versions	Region/Country	SMPS	Detachable mains cords
12/05	EUROPE/UK	1) 100 ~240Vac nom. (wide range from 90V~264Vac limit) used in all versions except India. Frequency: 47~63Hz.	EU(/12)round 2-pin & UK(/05) 3-pin
37	NAFTA		UL flat pin (non-polarized)
55	LATAM		INMETRO certified round 2-pin
98	APAC		EU round 2-pin
94	India	2) 100 ~310Vac limit (India compatible with up cost) used only for India. Frequency: 47~63Hz.	EU (/12) round 2-pin

All requirements per defined for each country should be met with sufficient testing.

4.1.2 Surge Immunity (Lightning Test)

The product shall withstand mains interference's of:

Differential mode:

- 2kV/2 ohm criteria C for Europe.
- 6kV/12 ohm criteria C for NAFTA.

Parameters:

- Bi-wave
- Open circuit voltage: 2/50us
- Short circuit current: 8/20us
- From +/1kV to +/2kV (for Europe) or +/6kV (for Nafta) in steps of 1kV.
- 10 shots per combination.
- One shot per minute.
- Serial impedance: 2 Ohm for Europe, 12Ohm for Nafta.
- Polarity and phase: Positive (phase 90°) & Negative (phase 270°)

Common mode:

- 6kV/2 ohm criteria C for Europe.
- 6kV/12 ohm criteria C for Nafta.

Parameters:

- Ring-wave (100kHz)
- From +/3kV to +/6kV in steps of 1 kV.
- 10 shots per combination.
- One shot per minute.
- Serial impedance: 2 Ohm for Europe, 12Ohm for Nafta
- Polarity and phase: Positive (phase 90°) & Negative (phase 270°)

Reference: IEC61000-4-5 and for USA: 3135 019 8029 Reliability evaluation.

Requirements:

- Apparatus should fulfil the leakage current requirements of IEC60065 point 9.1.1 (UAN-D1631)
- Defects or permanent deviations are not allowed.

Technical Specification and Connection Facilities

4.1.3 Mains Drop-out Immunity

The product shall withstand mains failures of:

- Variation 0% (=100% dip) at T-event = 50 mSec. Performance criterion B
- Variation 40% (=60% dip) at T-event = 100 mSec. Performance criterion B
- Variation 0% (=100% dip) at T-event = 5 Sec. Performance criterion C

Additional for USA apparatus: See 3135 019 8029 Reliability evaluation.

- Variation 0% (=100% dip) at T-event = 100 mSec in standby mode. Performance criterion B

Requirement:

No misoperation and no interference of user in order to guarantee continuation of performed function.

Reference: IEC61000-4-11 For measuring method refer to UAN-D1724, as far as applicable.

Performance criterions according to IEC61000-4-4 Amendment 1

Performance Requirement

Criterion A - No any degradation of specification.

Criterion B - Temporary degradation / self recoverable.

Criterion C - No damage, resolvable hang-up.

Criterion D - Not recoverable loss of function.

4.1.4 Power Consumption

Power consumption at nominal AC input:

1. CD play mode at 1/8 P-rated output power MCM7000:

$$\leq \frac{40}{\quad} \text{ W}$$

2. Low Power Standby Mode :

$$\leq \frac{0.5}{\quad} \text{ W}$$

Technical Specification and Connection Facilities

General Part			
Output Stage Protection:	NA	Temperature :	Yes
		Short Circuit:	Yes
Indicators		Clock Display Active	
Standby Mode Indicator:		LED Turns Off	
Power Standby Mode:			
Electrical Data			
DSC:	NA	Channel Difference:	±3dB
DBB:	NA	Hum (Vol _{min} --- Vol _{max} -20dB)	150nW
Bass:	Y	Residual Noise(Volume Minimum)	40nW
Treble:	Y	Channel Separation: 1kHz/10kHz	40dB/35dB
Loudness:	Y	THD,Maximal	<0.8%
		Signal to Noise Ratio(A-weighted):	≥82dB
		Crosstalk:	≥55dB
Audio Inputs			
Audio Input Sensitivity(±3dB) rated output power at 1kHz		Audio Output(*1)	
Tuner	FM 67.5kHz, Modulation (Limit:-6dB)	Line Out(Left/Right)	NA
CD/MP3	0dB track (Audio Disc 1, Track 1)	Headphone	15mW ± 2 dB, RL = 32Ω
USB	0dB 1kHz sinewave(2.0HS)		
AUX1(back)	1000mV ± 100mV; Rin ≥22kΩ		
MP3_link(front)	500mV ± 100mV; Rin ≥22kΩ		
IPOD Docking	800mV ± 100mV Rin ≥22kΩ		
Output Power(*1)	At THD=10%, 1kHz sinewave	MCM7000	
Main Operation for / all version (rms)		30W ± 1dB	(At Cold Condition with 10% THD)
Tuner output power(rms)		30W ± 1dB	(At Cold Condition with 10% THD)
Frequency Response(± 3dB)		30Hz-20kHz	
Loudspeaker(Boxes): Separable speaker box		Refer to package document of Speaker Box Assy	
Speaker driver Impedance: Right/Left:		4Ω @ 30 Hz ~ 20kHz(-3db)	
	Subwoofer:		

REMARKS:

Electrical Parameters are to be measured at Speaker Terminals across rated impedance Load(6ohm) with Rated Input Signal in CD Mode setting in DBB/Loudness Off and Pre-eq at Flat unless specified otherwise.

Technical Specification and Connection Facilities

5.TUNER

FM use Silicon Lab Si4704/4705(w/RDS)							
GENERAL PART							
WAVE RANGE	VERSION	TOLERANCE	TUNING GRID				
FM 87.5 – 108.00 MHz	/05/12	QUARTZ PRECISION	50kHz				
AERIAL							
FM : PIG TAIL ANT WIRE 75Ω							
ELECTRICAL DATA							
				FM	Nom	Limit	Unit
				- 3 dB Limiting Point	20	26	dBf
				Search Tuning Sensitivity(at stereo mode)	35	41	
				Search time digital tuning system.	-	60	s
				IF	10.7	-	MHz
				Stereo - 46 dB Quieting	48	51	dB
				Modulation Hum	50	45	
				S/N Ratio	50	45	
				Amplification Reverse	0	-4	dB
				Distortion (RF 1mV, Frq Dev.75 kHz)	2	3	%
				Overall Frequency Response: 63Hz – 12.5KHz	-	±3	dB
				Channel separation:400 / 1000 / 5000 Hz. RF input: 68 dBf	26/30/ 20	20/26/ 18	dB
Frequency (MHz)	Noise Limited Sensitivity 26 dB		Image Rejection	IF Rejection	Large Signal Handling	Selectivity S9/300 kHz	
FM	Nom.	18	30	64	1000	22	
88.0	Lim.	22	25	45	500	18 (*1)	
FM	Nom.	18	30	64	1000	22	
98.0	Lim.	22	25	45	500	18 (*1)	
FM	Nom.	18	30	60	116 dBf	45	
107.0	Lim.	22	25	65	108 dBf	25	
Units		dBf	DB	dB	mV/m	dB	
Susceptibility to unwanted signals(CPU,SMPS,AMP,DSP ...):				Limited(d B)	Normal (dB)	Remark	
				-15dB	-20dB	Refer to selfpollution curve	

Laser Beam Safety Precautions

This Blu-Ray player uses a pickup that emits a laser beam.

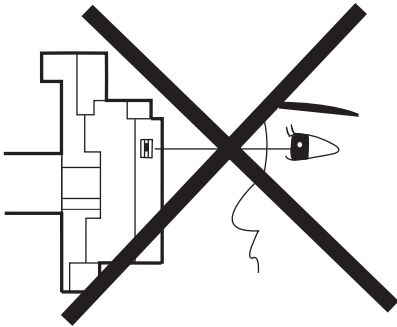

Do not look directly at the laser beam coming from the pickup or allow it to strike against your skin.

The laser beam is emitted from the location shown in the figure. When checking the laser diode, be sure to keep your eyes at least 30 cm away from the pickup lens when the diode is turned on. Do not look directly at the laser beam.

CAUTION: Use of controls and adjustments, or doing procedures other than those specified herein, may result in hazardous radiation exposure.

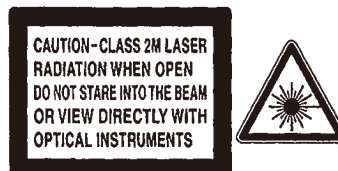
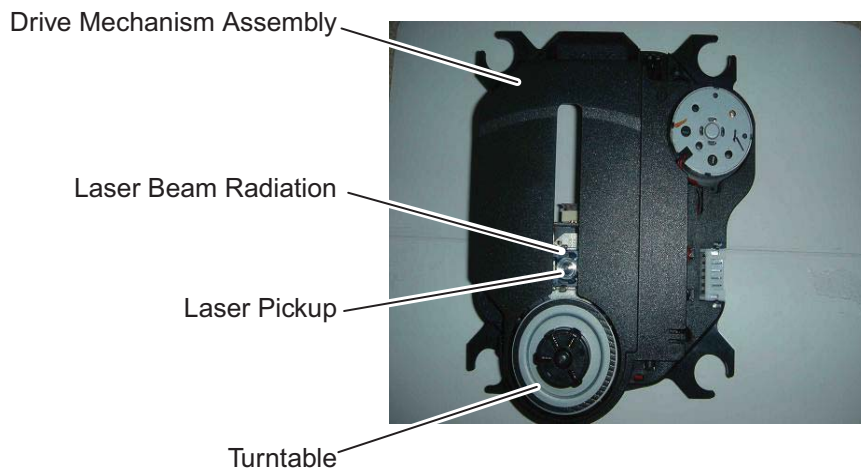

Location: Inside Top of Blu-Ray mechanism.

Important Safety Precautions

Important

Read and understand all instructions before you use your home theater. If damage is caused by failure to follow instructions, the warranty does not apply.

Safety

Risk of electric shock or fire!

- Never expose the product and accessories to rain or water. Never place liquid containers, such as vases, near the product. If liquids are spilled on or into the product, disconnect it from the power outlet immediately. Contact Philips Consumer Care to have the product checked before use.
- Never place the product and accessories near naked flames or other heat sources, including direct sunlight.
- Never insert objects into the ventilation slots or other openings on the product.
- Where the mains plug or an appliance coupler is used as the disconnect device, the disconnect device shall remain readily operable.
- Disconnect the product from the power outlet before lightning storms.
- When you disconnect the power cord, always pull the plug, never the cable.

Risk of short circuit or fire!

- Before you connect the product to the power outlet, ensure that the power voltage matches the value printed on the back or bottom of the product. Never connect the product to the power outlet if the voltage is different.

Risk of injury or damage to the home theater!

- For wall-mountable products, use only the supplied wall mount bracket. Secure the wall mount to a wall that can support the combined weight of the product and the wall mount. Koninklijke Philips Electronics N.V. bears no responsibility for improper wall mounting that results in accident, injury or damage.

- For speakers with stands, use only the supplied stands. Secure the stands to the speakers tightly. Place the assembled stands on flat, level surfaces that can support the combined weight of the speaker and stand.
- Never place the product or any objects on power cords or on other electrical equipment.
- If the product is transported in temperatures below 5°C, unpack the product and wait until its temperature matches room temperature before connecting it to the power outlet.
- Visible and invisible laser radiation when open. Avoid exposure to beam.
- Do not touch the disc optical lens inside the disc compartment.

Risk of overheating!

- Never install this product in a confined space. Always leave a space of at least four inches around the product for ventilation. Ensure curtains or other objects never cover the ventilation slots on the product.

Risk of contamination!

- Do not mix batteries (old and new or carbon and alkaline, etc.).
- Remove batteries if they are exhausted or if the remote control is not to be used for a long time.
- Batteries contain chemical substances, they should be disposed of properly.

Product care

- Do not insert any objects other than discs into the disc compartment.
- Do not insert warped or cracked discs into the disc compartment.
- Remove discs from the disc compartment if you are not using the product for an extended period of time.
- Only use microfiber cloth to clean the product.

Important Safety Precautions

Disposal of your old product and batteries



Your product is designed and manufactured with high quality materials and components, which can be recycled and reused.



When this crossed-out wheeled bin symbol is attached to a product it means that the product is covered by the European Directive 2002/96/EC. Please inform yourself about the local separate collection system for electrical and electronic products.

Please act according to your local rules and do not dispose of your old products with your normal household waste.

Correct disposal of your old product helps to prevent potential negative consequences for the environment and human health.



Your product contains batteries covered by the European Directive 2006/66/EC, which cannot be disposed with normal household waste.

Please inform yourself about the local rules on separate collection of batteries because correct disposal helps to prevent negative consequences for the environmental and human health.

Safety Check after Servicing

Examine the area surrounding the repaired location for damage or deterioration. Observe that screws, parts, and wires have been returned to their original positions. Afterwards, do the following tests and confirm the specified values to verify compliance with safety standards.

1. Clearance Distance

When replacing primary circuit components, confirm specified clearance distance (d) and (d') between soldered terminals, and between terminals and surrounding metallic parts. (See Fig. 1)

Table 1: Ratings for selected area

AC Line Voltage	Clearance Distance (d), (d')
110V~220V	≥ 3.2 mm (0.126 inches)

Note: This table is unofficial and for reference only. Be sure to confirm the precise values.

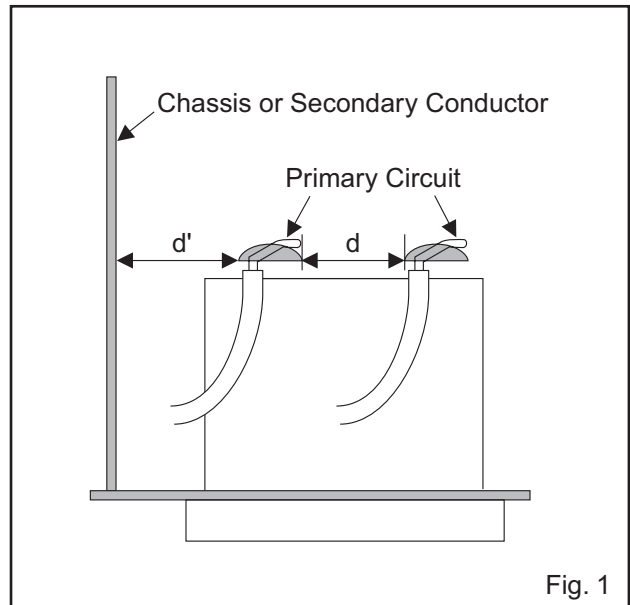

Fig. 1

2. Leakage Current Test

Confirm the specified (or lower) leakage current between B (earth ground, power cord plug prongs) and externally exposed accessible parts (RF terminals, antenna terminals, video and audio input and output terminals, microphone jacks, earphone jacks, etc.) is lower than or equal to the specified value in the table below.

Measuring Method (Power ON):

Insert load Z between B (earth ground, power cord plug prongs) and exposed accessible parts. Use an AC voltmeter to measure across the terminals of load Z . See Fig. 2 and the following table.

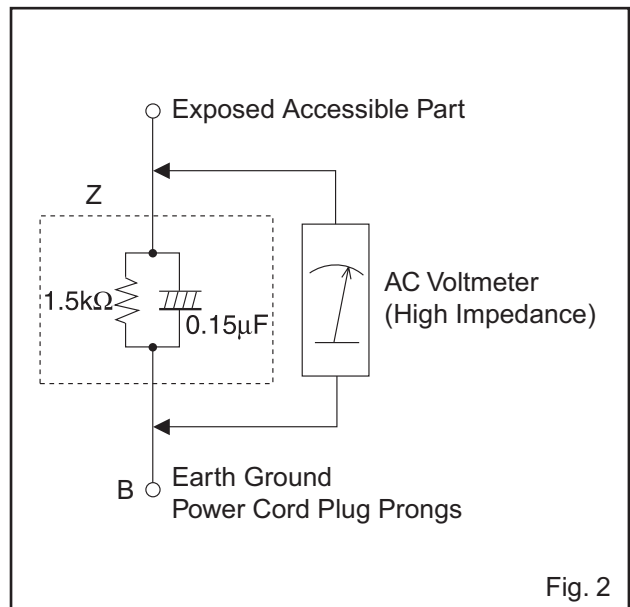

Fig. 2

Table 2: Leakage current ratings for selected areas

AC Line Voltage	Load Z	Leakage Current (i)	Earth Ground (B) to:
110V~220V	0.15 μ F CAP. & 1.5 k Ω RES. Connected in parallel	$i \leq 0.5$ mA Peak	Exposed accessible parts

Note: This table is unofficial and for reference only. Be sure to confirm the precise values.

Safety Information, General Notes & Lead Free Requirements

1 Safety Instructions

1.1 General Safety

Safety regulations require that during a repair:

- Connect the unit to the mains via an isolation transformer.
- Replace safety components, indicated by the symbol ▲, only by components identical to the original ones. Any other component substitution (other than original type) may increase risk of fire or electrical shock hazard.

Safety regulations require that after a repair, you must return the unit in its original condition. Pay, in particular, attention to the following points:

- Route the wires/cables correctly, and fix them with the mounted cable clamps.
- Check the insulation of the mains lead for external damage.
- Check the electrical DC resistance between the mains plug and the secondary side:
 1. Unplug the mains cord, and connect a wire between the two pins of the mains plug.
 2. Set the mains switch to the 'on' position (keep the mains cord unplugged!).
 3. Measure the resistance value between the mains plug and the front panel, controls, and chassis bottom.
 4. Repair or correct unit when the resistance measurement is less than 1 MΩ.
 5. Verify this, before you return the unit to the customer/user (ref. UL-standard no. 1492).
 6. Switch the unit 'off', and remove the wire between the two pins of the mains plug.

1.2 Laser Safety

This unit employs a laser. Only qualified service personnel may remove the cover, or attempt to service this device (due to possible eye injury).

Laser Device Unit

Type	:AlGaInN(BD) :AlGaInP(DVD) : AlGaInP(CD)
Wavelength	: 650 nm (DVD) : 780 nm (VCD/CD) : 405nm(BD)
Output Power	: 20 mW (DVD+RW writing) : 0.8 mW (DVD reading) : 0.3 mW (VCD/CD reading)
Beam divergence	: 60 degree

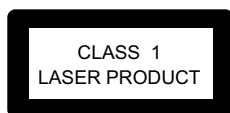

Figure 2-1

Note: Use of controls or adjustments or performance of procedure other than those specified herein, may result in hazardous radiation exposure. Avoid direct exposure to beam.

2 Warnings

2.1 General

- All ICs and many other semiconductors are susceptible to electrostatic discharges (ESD, ▲). Careless handling during repair can reduce life drastically. Make sure that, during repair, you are at the same potential as the mass of the set by a wristband with resistance. Keep components and tools at this same potential. Available ESD protection equipment:
 - Complete kit ESD3 (small tablemat, wristband, connection box, extension cable and earth cable) 4822 310 10671.
 - Wristband tester 4822 344 13999.
- Be careful during measurements in the live voltage section. The primary side of the power supply, including the heatsink, carries live mains voltage when you connect the player to the mains (even when the player is 'off!'). It is possible to touch copper tracks and/or components in this unshielded primary area, when you service the player. Service personnel must take precautions to prevent touching this area or components in this area. A 'lightning stroke' and a stripe-marked printing on the printed wiring board, indicate the primary side of the power supply.
- Never replace modules, or components, while the unit is 'on'.

2.2 Laser

- The use of optical instruments with this product, will increase eye hazard.
- Only qualified service personnel may remove the cover or attempt to service this device, due to possible eye injury.
- Repair handling should take place as much as possible with a disc loaded inside the player.
- Text below is placed inside the unit, on the laser cover shield:

CAUTION VISIBLE AND INVISIBLE LASER RADIATION WHEN OPEN AVOID EXPOSURE TO BEAM
 ADVARSEL SYNLIG OG USYNLIG LASERSTRÅLING VED ÅBNING UNDGÅ UDSÆTTELSE FOR STRÅLING
 ADVARSEL SYNLIG OG USYNLIG LASERSTRÅLING NÅR DEKSEL ÅPNES UNNGÅ EKSPONERING FOR STRÅLEN
 VARNING SYNLIG OCH OSYNLIG LASERSTRÅLING NÅR DENNA DEL ÅR ÖPPNAD BETRÄKTA EJ STRÅLEN
 VARO! AVATTAESSA OLET ALTIINA NÄKYVÄLLE JA NÄKYMÄTTÖMÄLLE LASER SÄTEILYLLE. ÄLÄ KATSO SÄTEESEEN
 VORSICHT SICHTBARE UND UNSICHTBARE LASERSTRAHLUNG WENN ABDECKUNG GEÖFFNET NICHT DEM STRAHL AUSSETZEN
 DANGER VISIBLE AND INVISIBLE LASER RADIATION WHEN OPEN AVOID DIRECT EXPOSURE TO BEAM
 ATTENTION RAYONNEMENT LASER VISIBLE ET INVISIBLE EN CAS D'OUVERTURE EXPOSITION DANGEREUSE AU FAISCEAU

Figure 2-2

Circuit Board Indications

1. The output pin of the 3 pin Regulator ICs is indicated as shown.

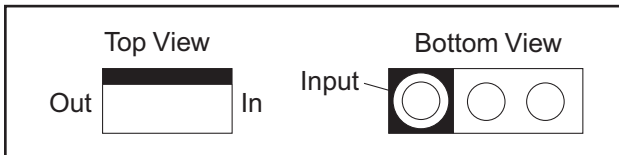

2. For other ICs, pin 1 and every fifth pin are indicated as shown.

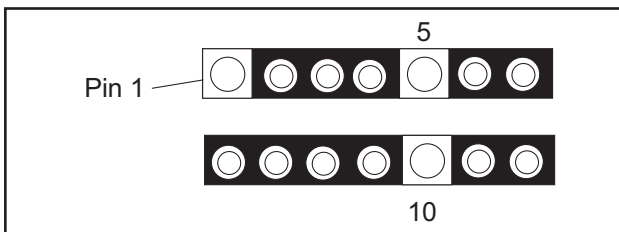

3. The 1st pin of every male connector is indicated as shown.

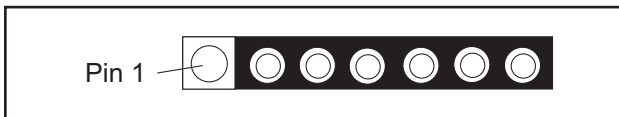

Instructions for Connectors

1. When you connect or disconnect the FFC (Flexible Foil Connector) cable, be sure to first disconnect the AC cord.
2. FFC (Flexible Foil Connector) cable should be inserted parallel into the connector, not at an angle.

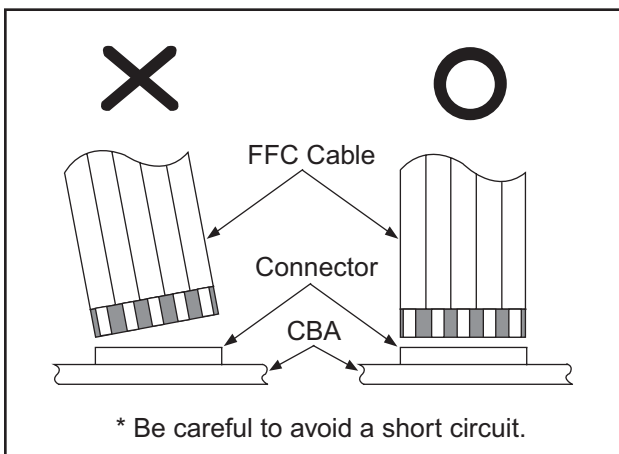

Pb (Lead) Free Solder

When soldering, be sure to use the Pb free solder.

Information about lead-free soldering

Philips CE is producing lead-free sets from 1.1.2005 onwards.

IDENTIFICATION

Regardless of special logo (not always indicated)



One must treat all sets from **1 Jan 2005** onwards, according to the next rule:

Serial Number gives a 14-digit. Digit 5&6 shows the YEAR, and digit 7&8 shows the WEEK.

So from **0501** onwards=from 1 Jan 2005 onwards

Important note : In fact also products of year 2004 must be treated in this way as long as you avoid mixing solder-alloys (leaded/ lead-free). So best to always use SAC305 and the higher temperatures belong to this.

Due to lead-free technology some rules have to be respected by the workshop during a repair:

- Use only lead-free solder alloy Philips SAC305 with order code 0622 149 00106. If lead-free solder-paste is required, please contact the manufacturer of your solder-equipment. In general use of solder-paste within workshops should be avoided because paste is not easy to store and to handle.
- Use only adequate solder tools applicable for lead-free solder alloy. The solder tool must be able
 - To reach at least a solder-temperature of 400°C,
 - To stabilize the adjusted temperature at the solder-tip
 - To exchange solder-tips for different applications.
- Adjust your solder tool so that a temperature around **360°C - 380°C** is reached and stabilized at the solder joint. Heating-time of the solder-joint should not exceed ~ 4 sec. Avoid temperatures above 400°C otherwise wear-out of tips will rise drastically and flux-fluid will be destroyed. To avoid wear-out of tips switch off un-used equipment, or reduce heat.
- Mix of lead-free solder alloy / parts with leaded solder alloy / parts is possible but PHILIPS recommends strongly to avoid mixed solder alloy types (leaded and lead-free).
If one cannot avoid or does not know whether product is lead-free, clean carefully the solder-joint from old solder alloy and re-solder with new solder alloy (SAC305).
- Use only original spare-parts listed in the Service-Manuals. Not listed standard-material (commodities) has to be purchased at external companies.

Standard Notes for Servicing, Lead Free Requirements & Handling Flat Pack IC

- Special information for BGA-ICs:

- always use the 12nc-recognizable soldering temperature profile of the specific BGA (for desoldering always use the lead-free temperature profile, in case of doubt)
- lead free BGA-ICs will be delivered in so-called 'dry-packaging' (sealed pack including a silica gel pack) to protect the IC against moisture. After opening, dependent of MSL-level seen on indicator-label in the bag, the BGA-IC possibly still has to be baked dry. (MSL=Moisture Sensitivity Level). This will be communicated via AYS-website. Do not re-use BGAs at all.

- For sets produced before 1.1.2005 (except products of 2004), containing leaded solder-alloy and components, all needed spare-parts will be available till the end of the service-period. For repair of such sets nothing changes.

- On our website www.atyourservice.ce.Philips.com you find more information to:

- BGA-de-/soldering (+ baking instructions)
- Heating-profiles of BGAs and other ICs used in Philips-sets

You will find this and more technical information within the "magazine", chapter "workshop news".

For additional questions please contact your local repair-helpdesk.

How to Remove / Install Flat Pack-IC

1. Removal

With Hot-Air Flat Pack-IC Desoldering Machine:

1. Prepare the hot-air flat pack-IC desoldering machine, then apply hot air to the Flat Pack-IC (about 5 to 6 seconds). (Fig. S-1-1)

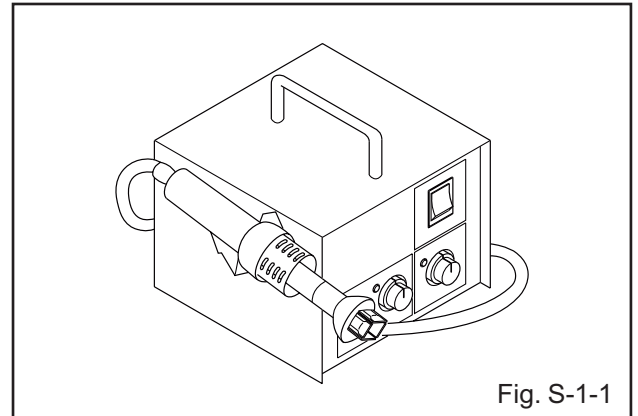

2. Remove the flat pack-IC with tweezers while applying the hot air.
3. Bottom of the flat pack-IC is fixed with glue to the CBA; when removing entire flat pack-IC, first apply soldering iron to center of the flat pack-IC and heat up. Then remove (glue will be melted). (Fig. S-1-6)
4. Release the flat pack-IC from the CBA using tweezers. (Fig. S-1-6)

CAUTION:

1. The Flat Pack-IC shape may differ by models. Use an appropriate hot-air flat pack-IC desoldering machine, whose shape matches that of the Flat Pack-IC.
2. Do not supply hot air to the chip parts around the flat pack-IC for over 6 seconds because damage to the chip parts may occur. Put masking tape around the flat pack-IC to protect other parts from damage. (Fig. S-1-2)

Standard Notes for Servicing, Lead Free Requirements & Handling Flat Pack IC

- The flat pack-IC on the CBA is affixed with glue, so be careful not to break or damage the foil of each pin or the solder lands under the IC when removing it.

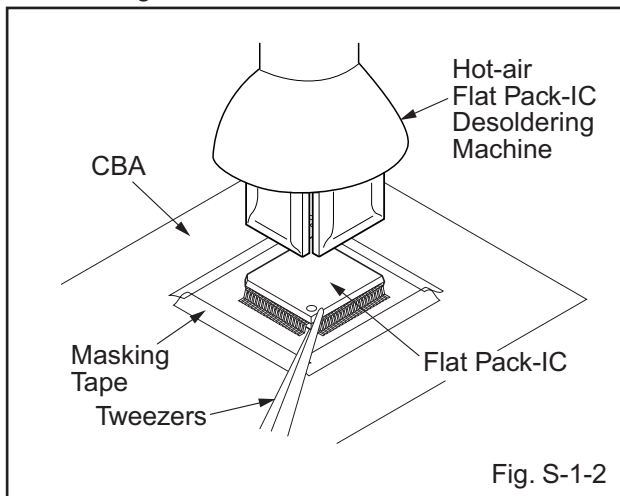

With Soldering Iron:

- Using desoldering braid, remove the solder from all pins of the flat pack-IC. When you use solder flux which is applied to all pins of the flat pack-IC, you can remove it easily. (Fig. S-1-3)

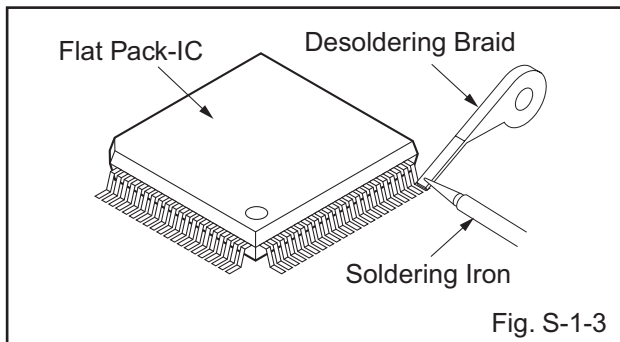

- Lift each lead of the flat pack-IC upward one by one, using a sharp pin or wire to which solder will not adhere (iron wire). When heating the pins, use a fine tip soldering iron or a hot air desoldering machine. (Fig. S-1-4)

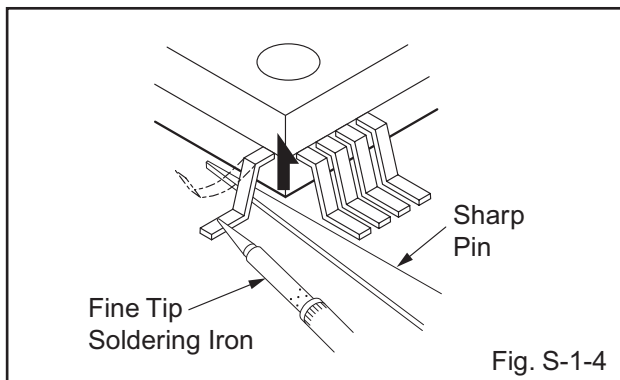

- Bottom of the flat pack-IC is fixed with glue to the CBA; when removing entire flat pack-IC, first apply soldering iron to center of the flat pack-IC and heat up. Then remove (glue will be melted). (Fig. S-1-6)

- Release the flat pack-IC from the CBA using tweezers. (Fig. S-1-6)

With Iron Wire:

- Using desoldering braid, remove the solder from all pins of the flat pack-IC. When you use solder flux which is applied to all pins of the flat pack-IC, you can remove it easily. (Fig. S-1-3)
- Affix the wire to a workbench or solid mounting point, as shown in Fig. S-1-5.
- While heating the pins using a fine tip soldering iron or hot air blower, pull up the wire as the solder melts so as to lift the IC leads from the CBA contact pads as shown in Fig. S-1-5.
- Bottom of the flat pack-IC is fixed with glue to the CBA; when removing entire flat pack-IC, first apply soldering iron to center of the flat pack-IC and heat up. Then remove (glue will be melted). (Fig. S-1-6)
- Release the flat pack-IC from the CBA using tweezers. (Fig. S-1-6)

Note: When using a soldering iron, care must be taken to ensure that the flat pack-IC is not being held by glue. When the flat pack-IC is removed from the CBA, handle it gently because it may be damaged if force is applied.

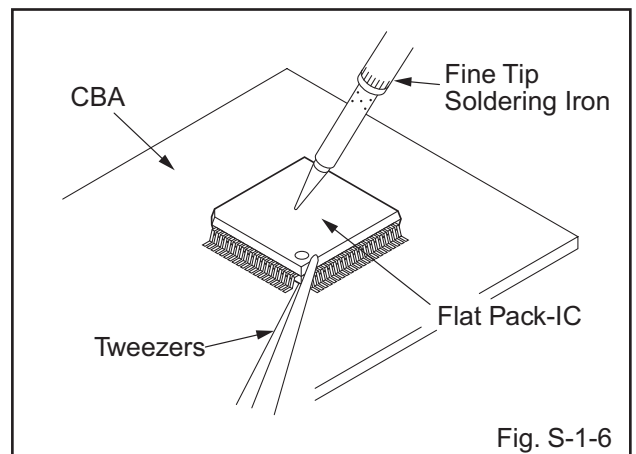
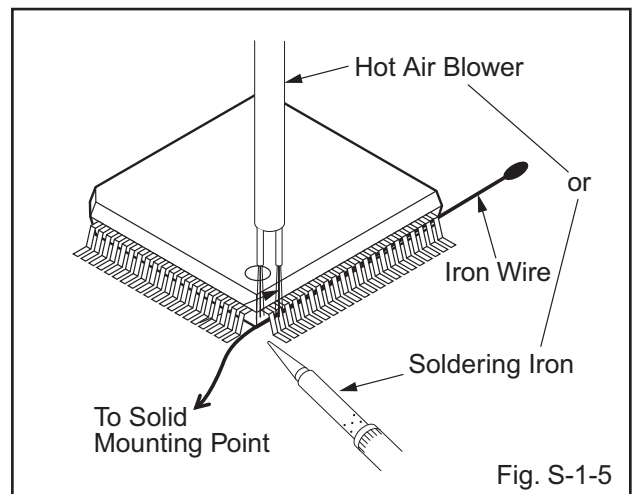

Standard Notes for Servicing, Lead Free Requirements & Handling Flat Pack IC

2. Installation

1. Using desoldering braid, remove the solder from the foil of each pin of the flat pack-IC on the CBA so you can install a replacement flat pack-IC more easily.
2. The "●" mark on the flat pack-IC indicates pin 1. (See Fig. S-1-7.) Be sure this mark matches the 1 on the PCB when positioning for installation. Then presolder the four corners of the flat pack-IC. (See Fig. S-1-8.)
3. Solder all pins of the flat pack-IC. Be sure that none of the pins have solder bridges.

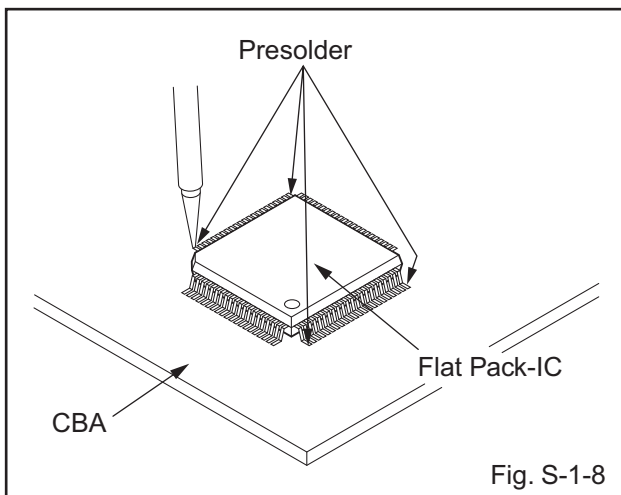
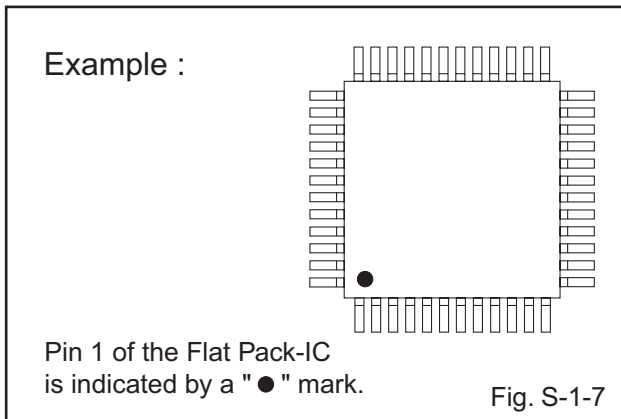

Instructions for Handling Semi-conductors

Electrostatic breakdown of the semi-conductors may occur due to a potential difference caused by electrostatic charge during unpacking or repair work.

1. Ground for Human Body

Be sure to wear a grounding band (1 M Ω) that is properly grounded to remove any static electricity that may be charged on the body.

2. Ground for Workbench

Be sure to place a conductive sheet or copper plate with proper grounding (1 M Ω) on the workbench or other surface, where the semi-conductors are to be placed. Because the static electricity charge on clothing will not escape through the body grounding band, be careful to avoid contacting semi-conductors with your clothing.

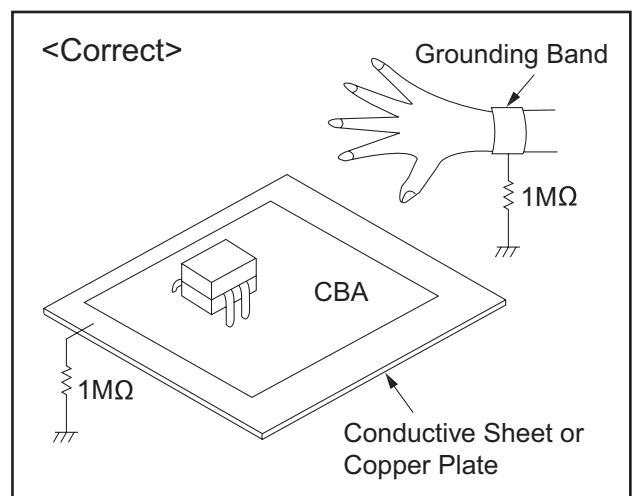
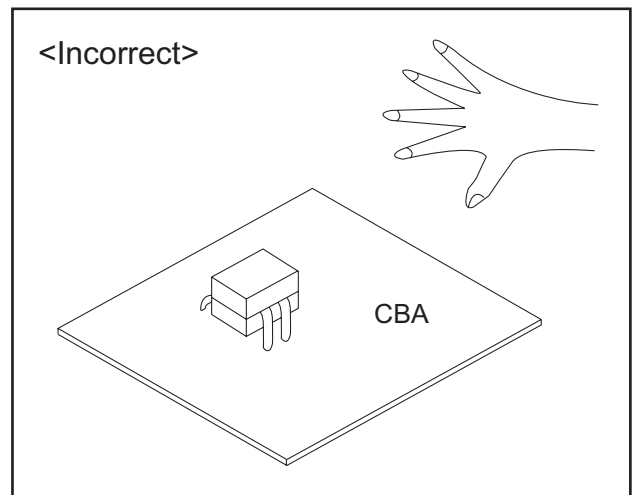

Direction of Use

*The following excerpt of the DFU/QSG serves as an introduction to the set. The Complete Direction for Use can be download in different languages from the internet site of Philips Customer care Center : www.support.philips.com

Overview of the main unit

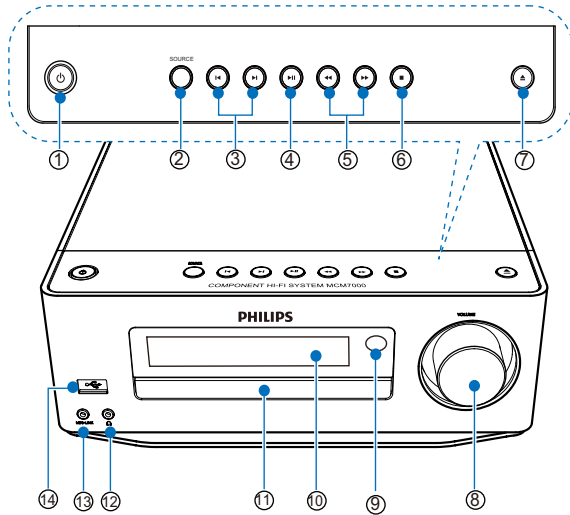

- ①
 - Switch to ECO Power or standby mode.
- ② SOURCE
 - Select a source.
- ③
 - Skip to the previous/next track.
 - Skip to the previous/next title or chapter.
 - Tune to a radio station.
- ④
 - Start or pause play.
- ⑤
 - Search backward or forward.
 - Search to a radio station.
- ⑥
 - Stop play.
 - Erase a program.
 - (In standby mode) Turn on/off Demo mode.
- ⑦
 - Open or close the disc compartment.
- ⑧ VOLUME
 - Adjust volume.
 - Adjust time.
- ⑨ IR sensor
 - Detect signals from the remote control. Always point the remote control at the IR sensor.
- ⑩ Display panel
 - Display information about current source.
- ⑪ Disc compartment
 - Hold the disc.

Overview of the main unit

- ⑫
 - Headphone socket.
- ⑬ MP3 LINK
 - Connect to an external audio device.
- ⑭
 - Connect to a USB flash drive.

Overview of Remote control

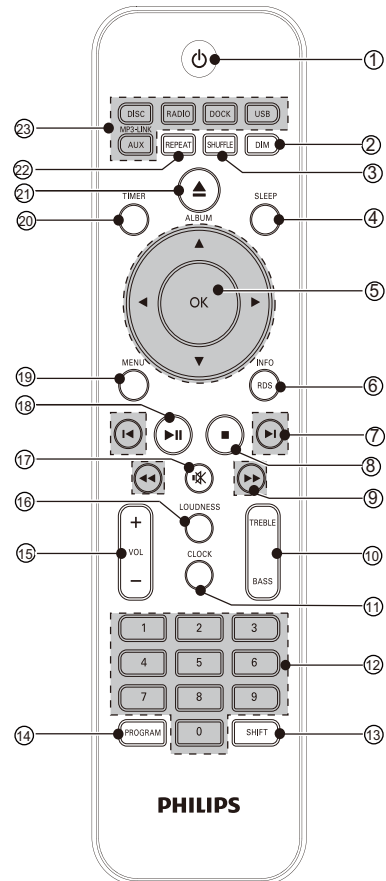

- ①
 - Switch to ECO Power or standby mode.
- ② DIM
 - Adjust brightness of display panel.
 - (Press and hold) Turn on or off the LED light at the bottom of the unit and at the volume knob.

Direction of Use

Remote control

③ SHUFFLE

- Play tracks randomly.

④ SLEEP

- Set the sleep timer.

⑤ ▲▼◀▶

- Navigate through menu.
- ALBUM▲▼: Skip to previous/next album; skip to a preset station.

OK

- Confirm an entry or selection.
- Select FM stereo or mono.

⑥ RDS/INFO

- For selected FM radio stations: display RDS information.
- Display the current status or the disc information.
- Display the ID3 information (if available) of MP3 tracks.

⑦ ◀▶

- Skip to the previous or next title, chapter, track, or radio station.

⑧ ■

- Stop play.
- Erase a program.
- (In standby mode) Turn on/off Demo mode.

⑨ ◀▶▶▶

- search backwards or forward.
- Search to a radio station.

⑩ TREBLE / BASS

- Activate treble/bass adjustment.

⑪ CLOCK

- Set the clock.
- Display the set clock.

⑫ Numeric keypad.

- Select a track directly.

⑬ SHIFT

- Enter a two or three-digit number (with the numeric keypad).

⑭ PROGRAM

- Program radio stations.
- Program tracks.

⑮ VOL +/-

- Adjust volume.
- Adjust time.

⑯ LOUDNESS

- Turn on or off automatic loudness adjustment.

⑰ 🔇

- Mute or restore volume.

⑱ ▶||

- Start or pause play.

⑲ MENU

- Access menu.
- This button is not workable for this model.

⑳ TIMER

- Set alarm timer.

㉑ ▲

- Open or close the disc compartment.

㉒ REPEAT

- Select a repeat play mode.

㉓ Source buttons

- Select a source.
- DOCK source is not available for this unit.

3 Get started

! Caution

- Use of controls or adjustments or performance of procedures other than herein may result in hazardous radiation exposure or other unsafe operation.

Always follow the instructions in this chapter in sequence.

If you contact Philips, you will be asked for the model and serial number of this apparatus. The model number and serial number are on the back of the apparatus. Write the numbers here:

Model No. _____

Serial No. _____

Connect speakers

≡ Note

- Ensure that the colors of the speaker wires and terminals are matched.
- For optimal sound, use the supplied speakers only.
- Connect only speakers with impedance that is the same or higher than the supplied speakers. Refer to the Specifications section of this manual.

For the main unit side:

Connect the speaker wires and the main unit as the following graphic indicates:

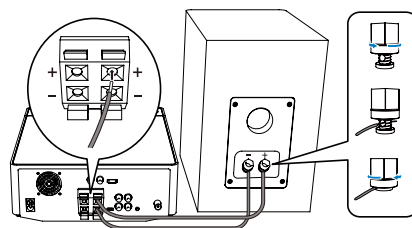

Direction of Use

For the speaker side:

- 1 Unscrew the speaker connectors.
- 2 For the left speaker, identify the speaker cable that is connected to the left connectors on the main unit.
- 3 Insert fully the red end of the speaker cable into the red (+) connector.
- 4 Screw the red (+) connector to secure the cable.
- 5 Insert fully the silver end of the speaker cable into the black (-) connector.
- 6 Screw the black (-) connector to secure the cable.
- 7 Repeat steps 2-6 for the right speaker.

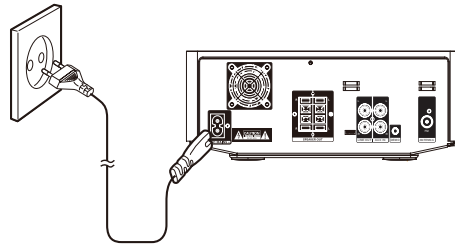

- 1 Connect the power cord to:
 - the AC~ socket on the main unit.
 - the power outlet.

Connect FM antenna

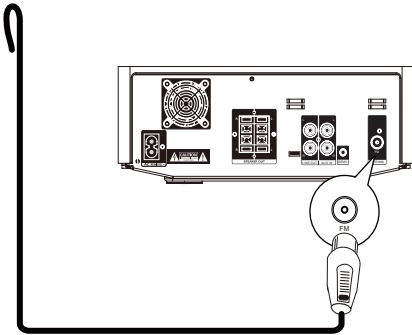

Tip

- For optimal reception, fully extend and adjust the position of the antenna.
- For better FM stereo reception, connect an outdoor FM antenna to the FM ANTENNA socket.
- The unit does not support MW radio reception.

- 1 Connect the supplied FM antenna to the FM ANTENNA socket on the main unit.

Connect power

Caution

- Risk of product damage! Ensure that the power supply voltage corresponds to the voltage printed on the back or the underside of the unit.
- Risk of electric shock! When you unplug the AC power cord, always pull the plug from the socket. Never pull the power cord.
- Before you connect the AC power cord, ensure that you have completed all other connections.

Cabinet Disassembly Instructions

1. Disassembly Flowchart

This flowchart indicates the disassembly steps to gain access to item(s) to be serviced. When reassembling, follow the steps in reverse order. Bend, route, and dress the cables as they were originally.

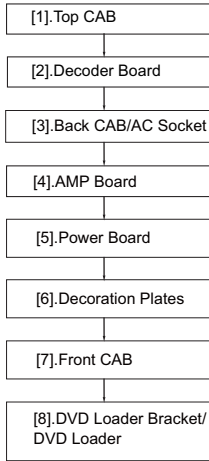

2. Disassembly Method

ID/Loc. NO.	Part	Removal		
		Fig.NO.	Remove/Unhook /Unlock/Release/ Unplug/Desolder	Note
[1]	Top CAB	D1	7(A01) D3*12 BA	
[2]	Decoder Board	D2	2(A02)D3X8 PA 3(A03)D3X8 BA	
[3]	Back CAB AC Socket	D3	5 (A04) D3X5 PMTT 1 (A05) D3X8 BA 2 (A06) D3X8 PA	
[4]	AMP Board	D4	1 (A07) D3X8 BM 1 (A08) D3X5 PMTT	
[5]	Power Board	D5	1 (A09) D3X8 BA	
[6]	Decoration Plates	D6	2 (A10) D3X8 FA	
[7]	Front CAB	D7		
[8]	DVD Loader Bracket/DVD Loader	D8	4 (A011) D3X5 PM 4 (A012) D3X12 BA	

Note:

- (1) Identification (location) No. of parts in the figures
- (2) Name of the part
- (3) Figure Number for reference
- (4) Identification of parts to be removed, unhooked, unlocked, released, unplugged, unclamped, or desoldered.

Axx = Screw, CNxx/Jxx/CONxx = Connector
D3.5X12BA is specification of screw.

* = Unhook, Unlock, Release, Unplug, or Desolder
e.g. 7(A01) = seven Screws

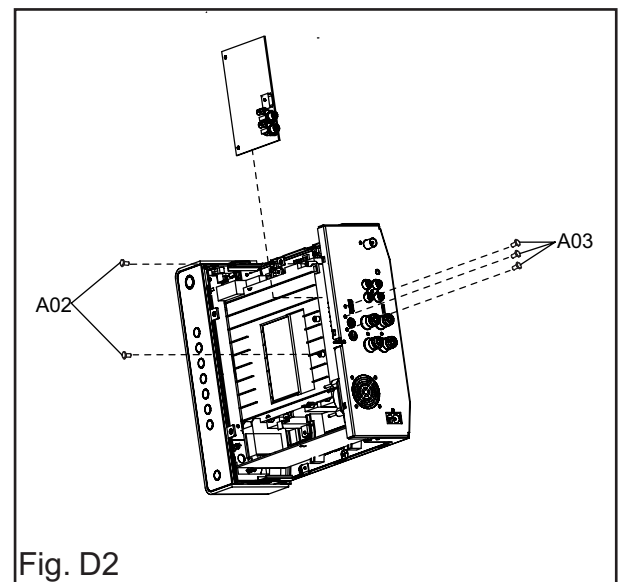
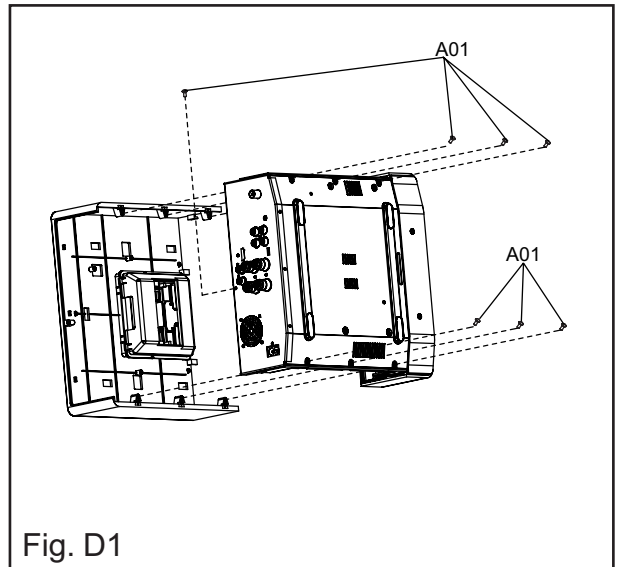

Cabinet Disassembly Instructions

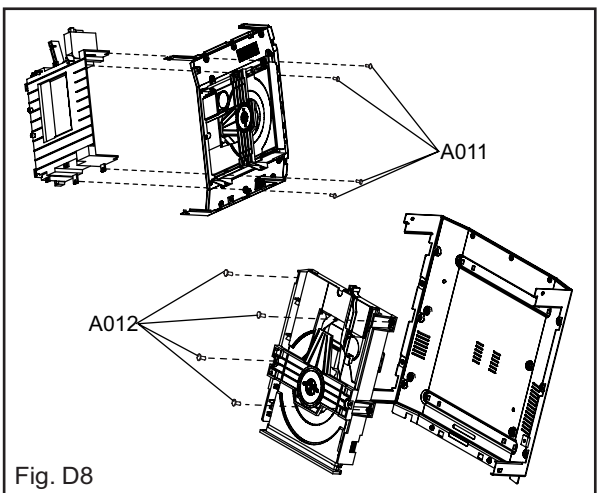
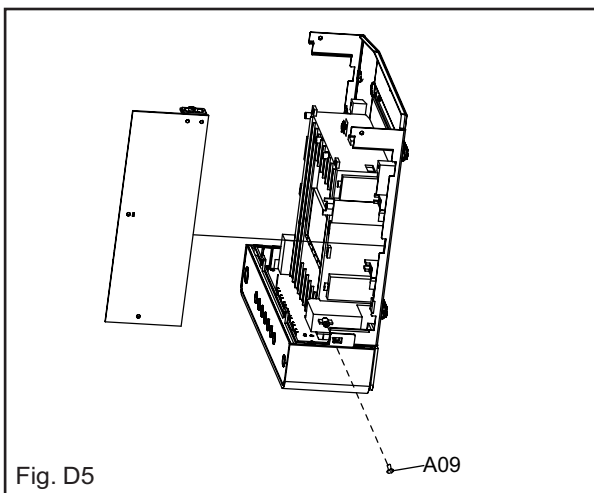
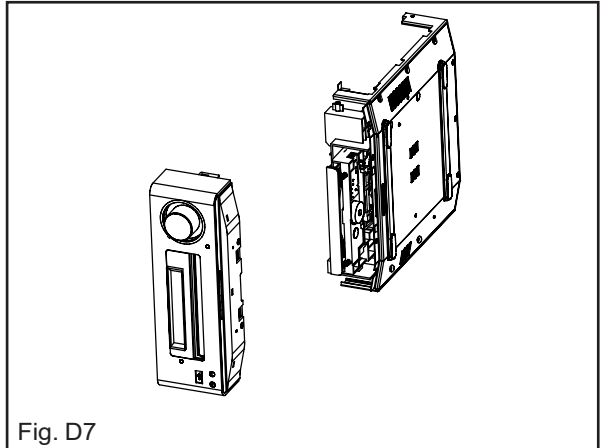
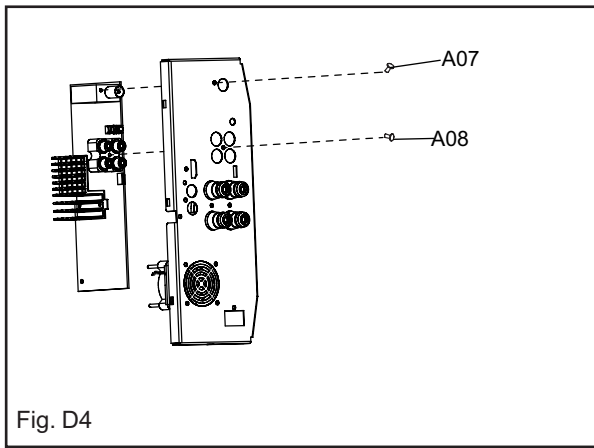
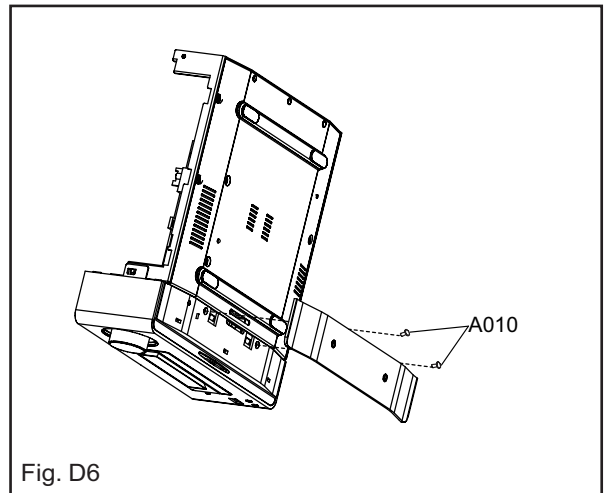
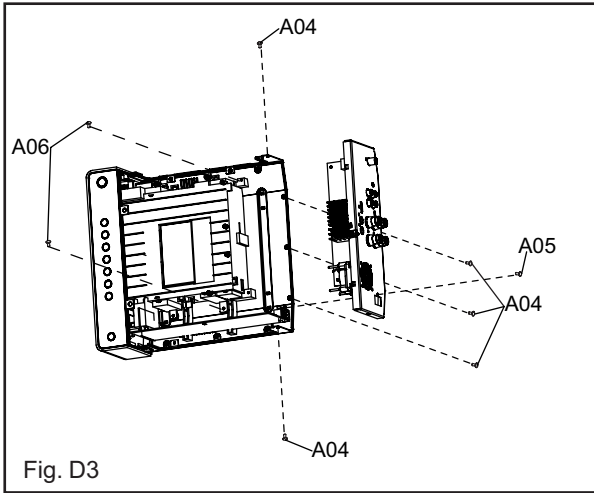

Troubleshooting

FLOW CHART NO.1

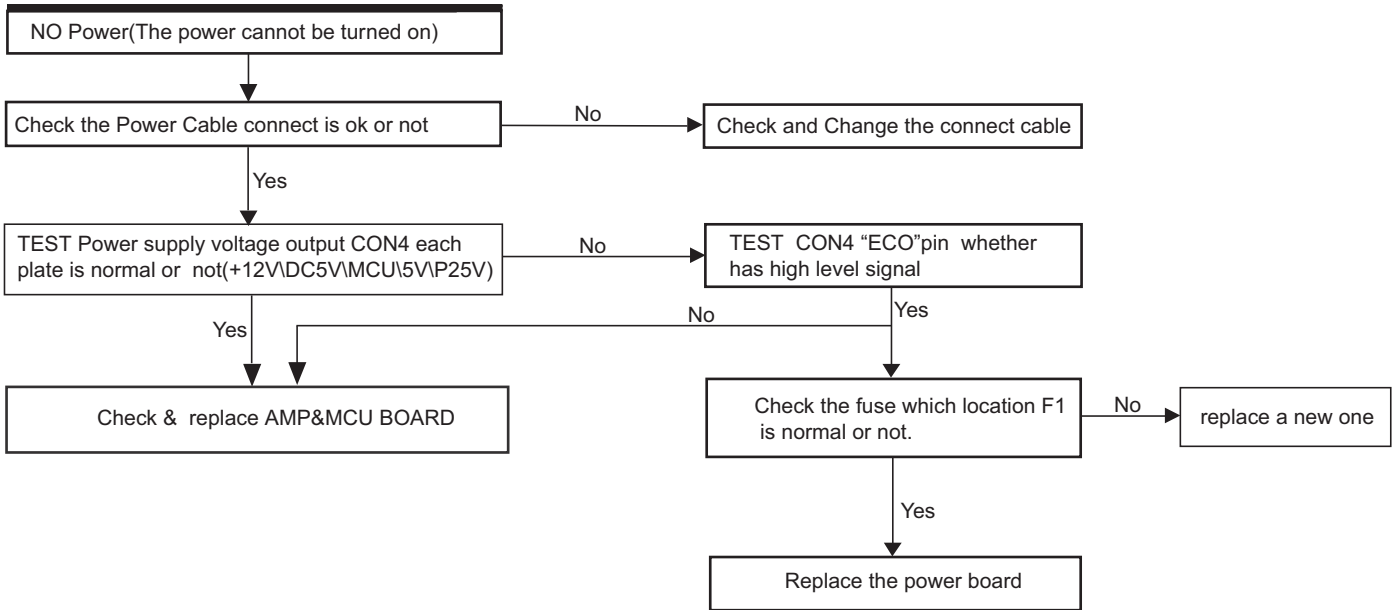

FLOW CHART NO.2

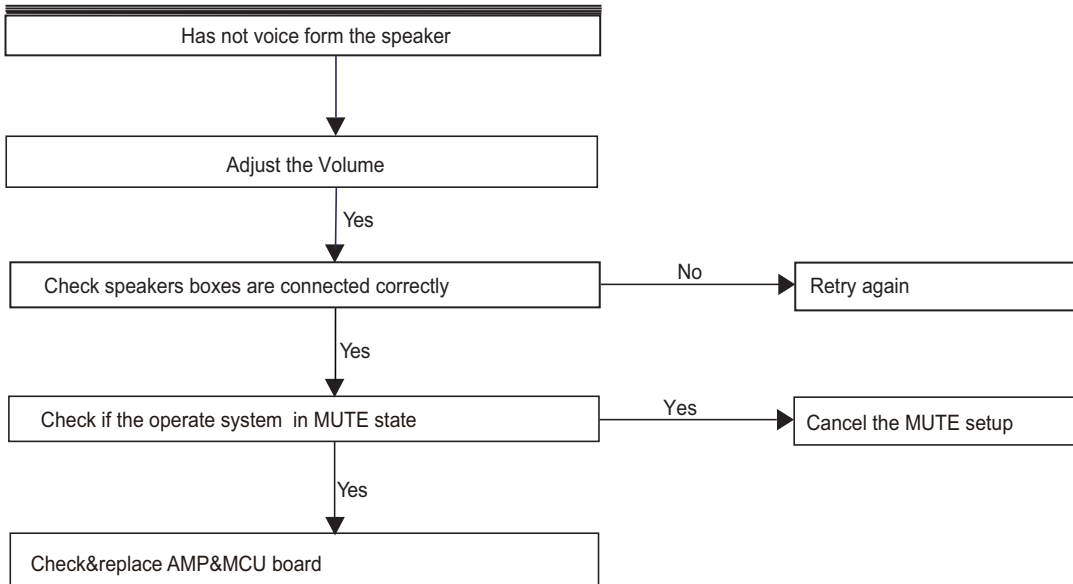

Troubleshooting

FLOW CHART NO.3

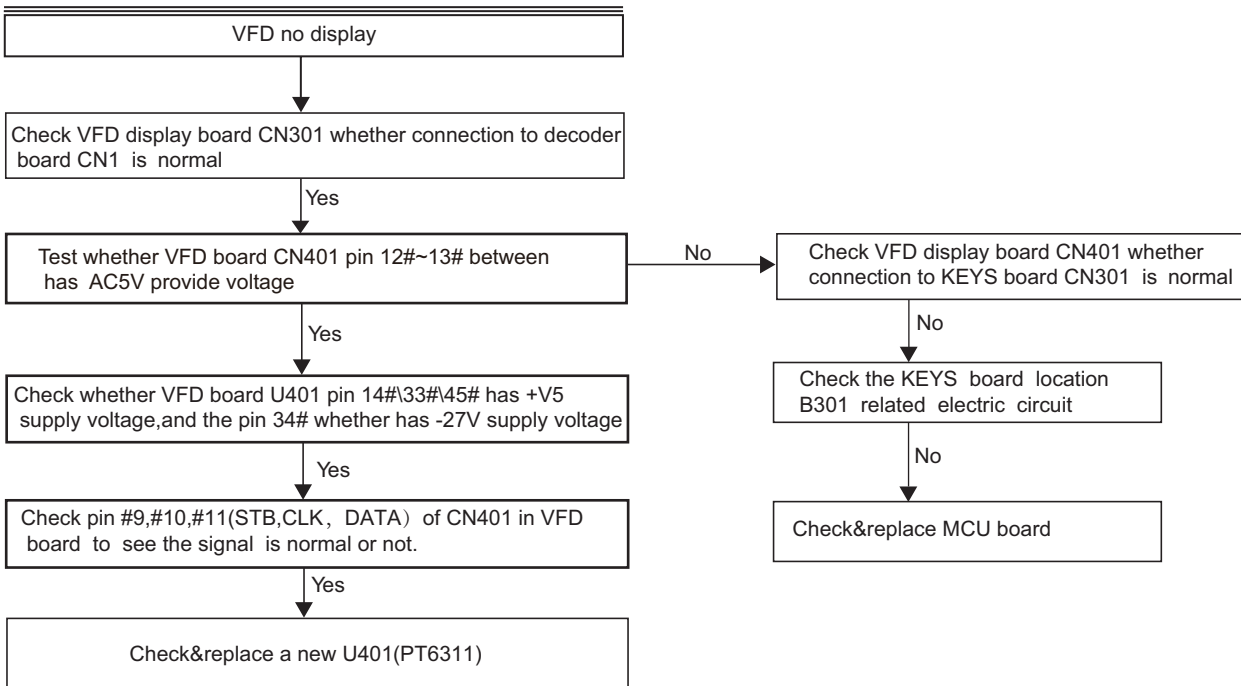

FLOW CHART NO.4

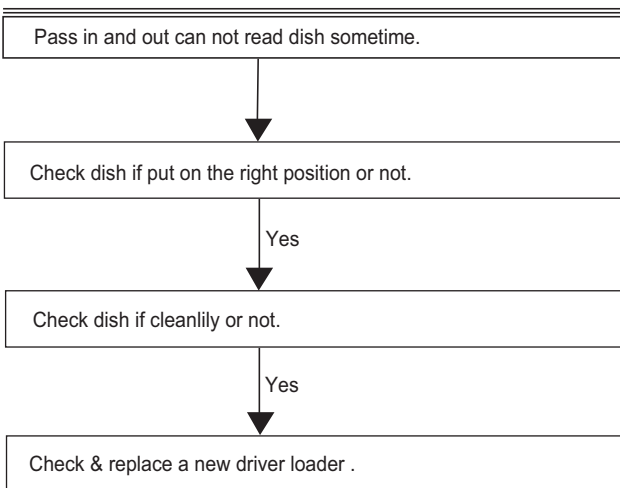

Block Diagram

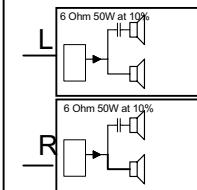
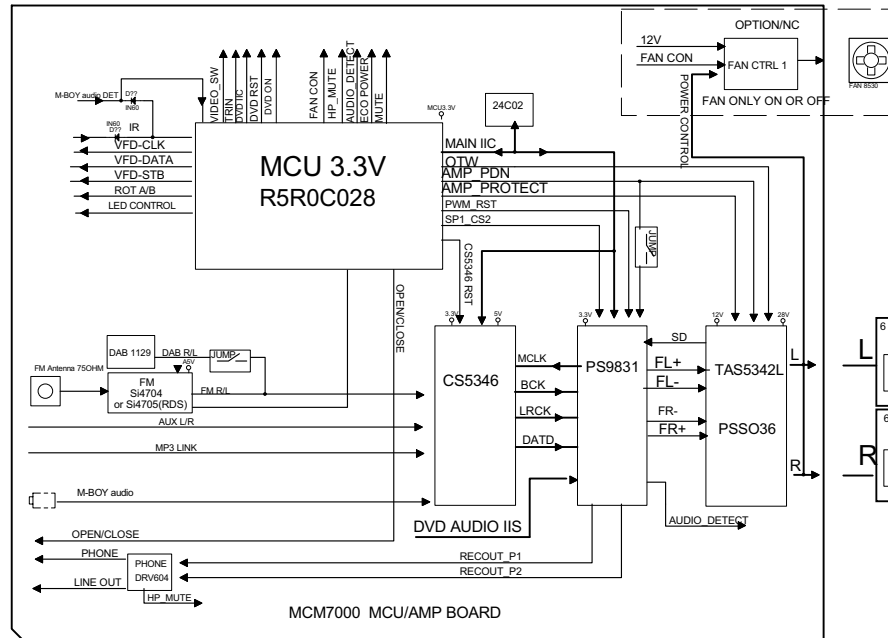
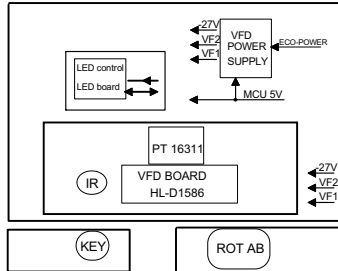
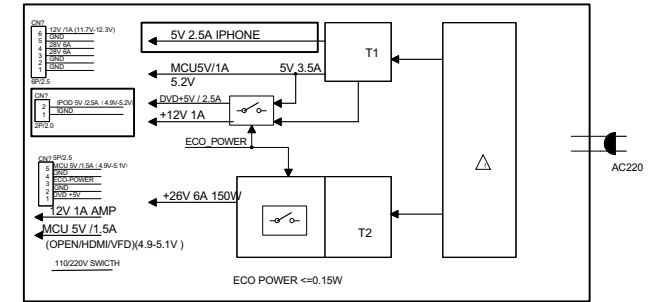
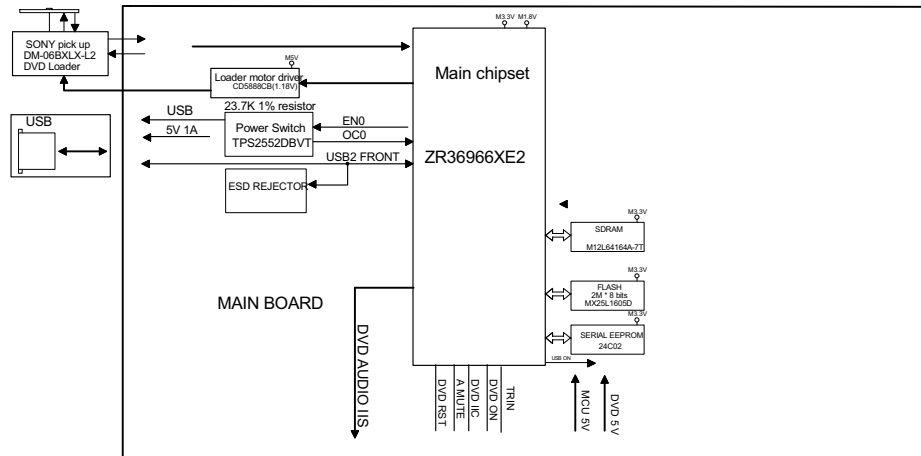

Wiring Diagram

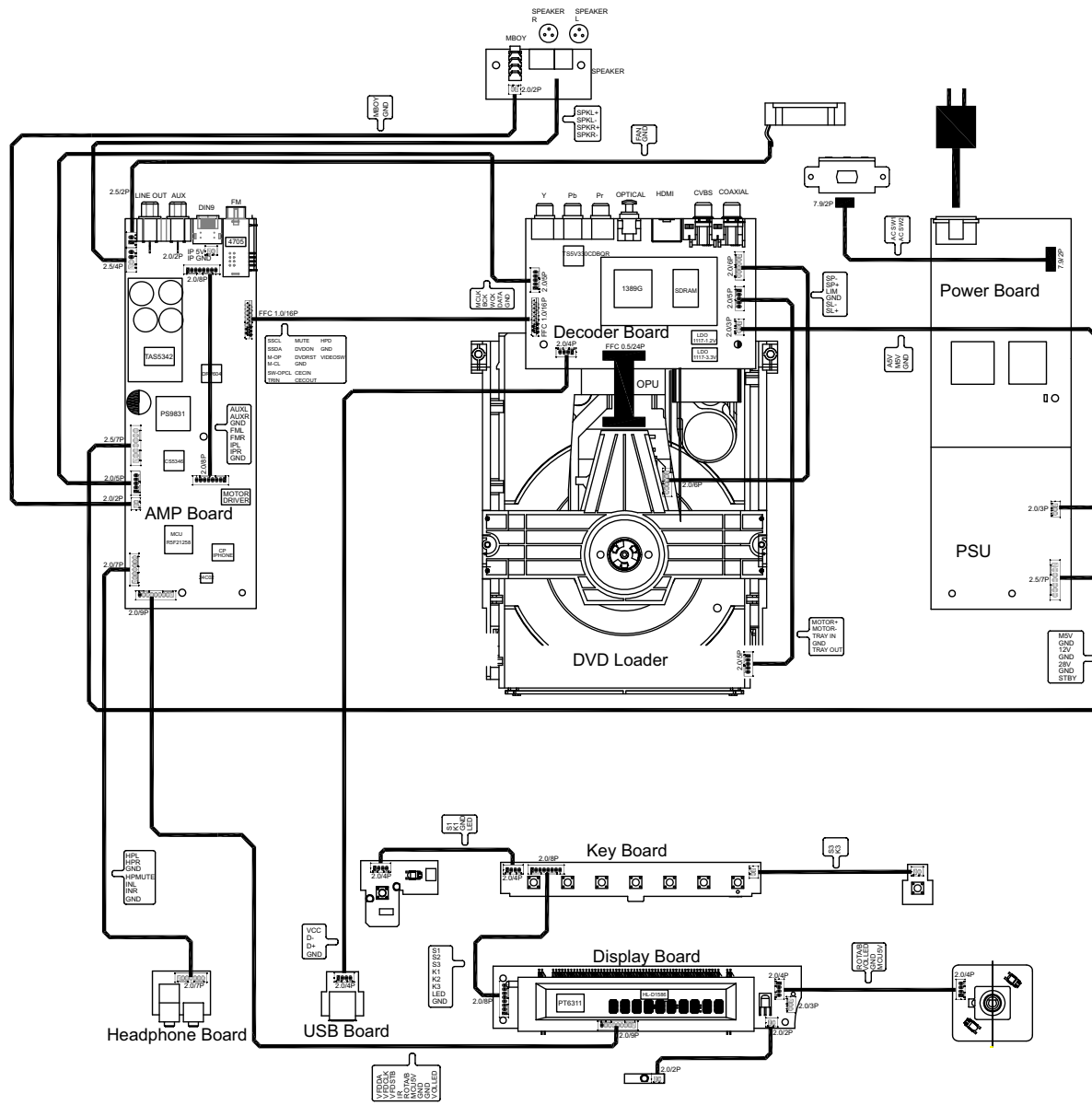

AMP Board -- Circuit Diagram

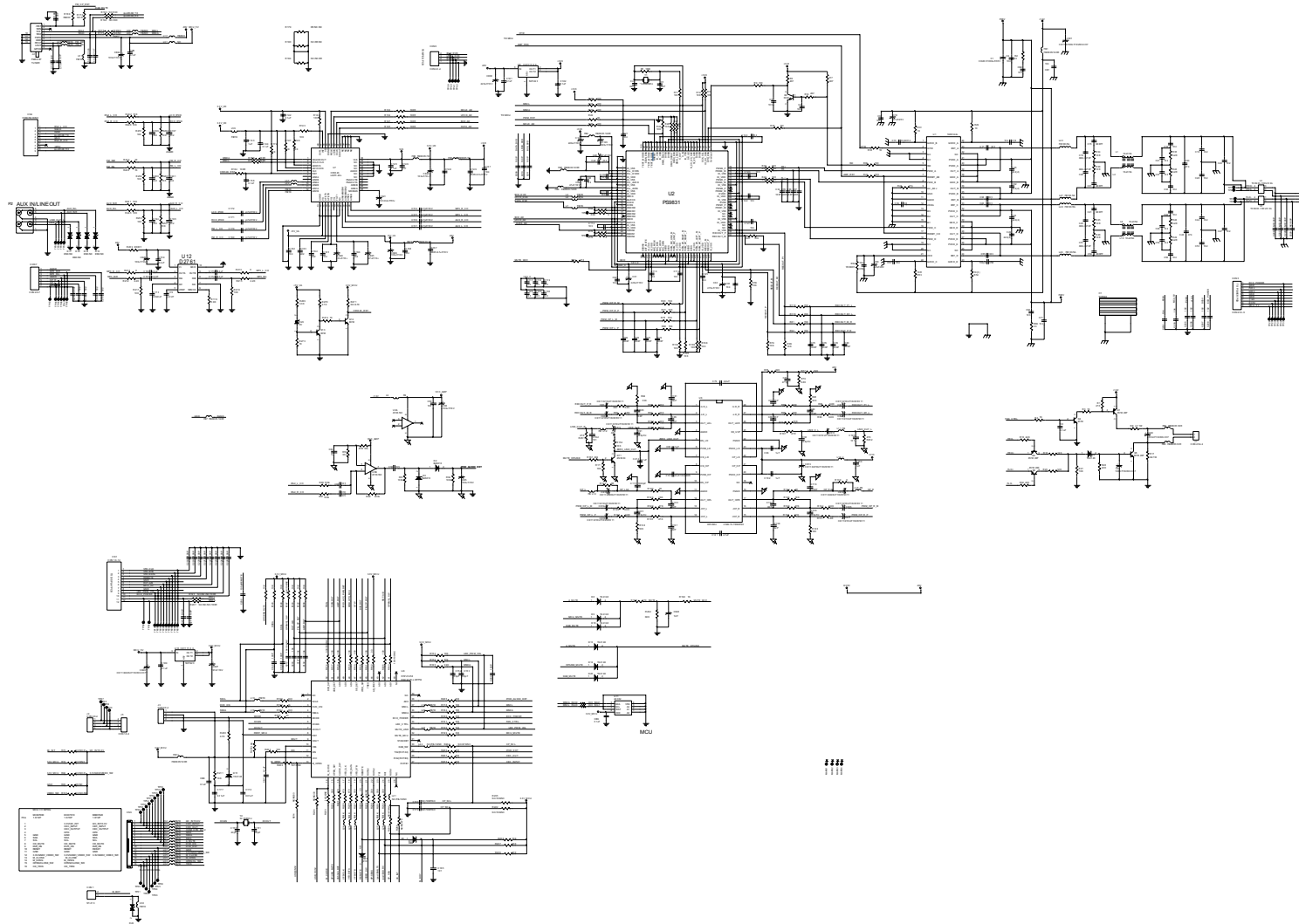

AMP BOARD -- Layout Diagram

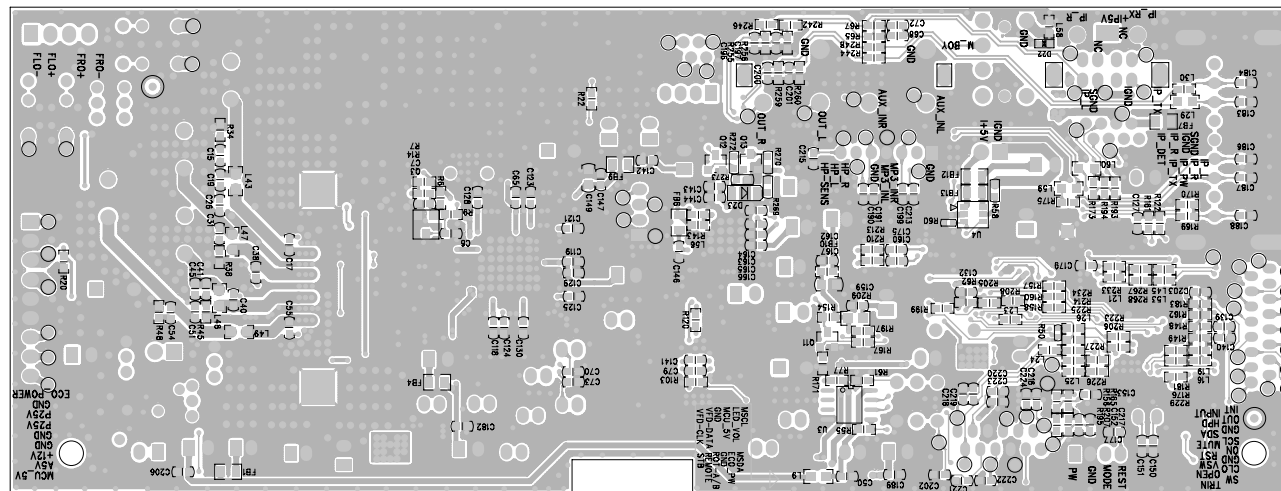
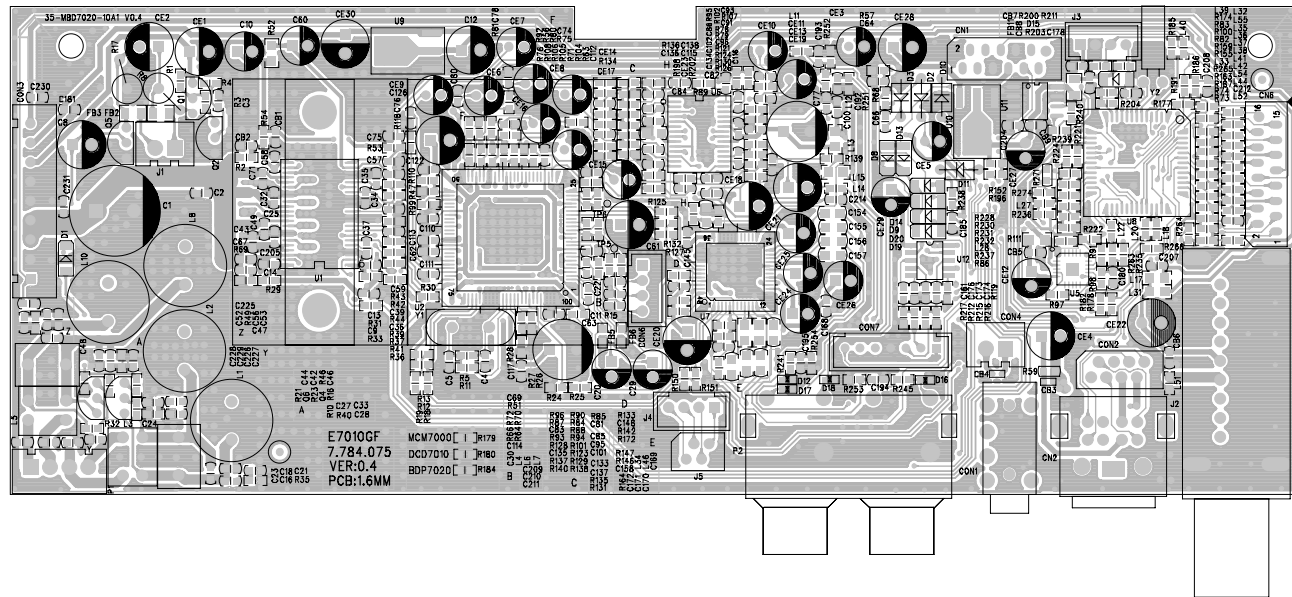

Display Board -- Circuit Diagram

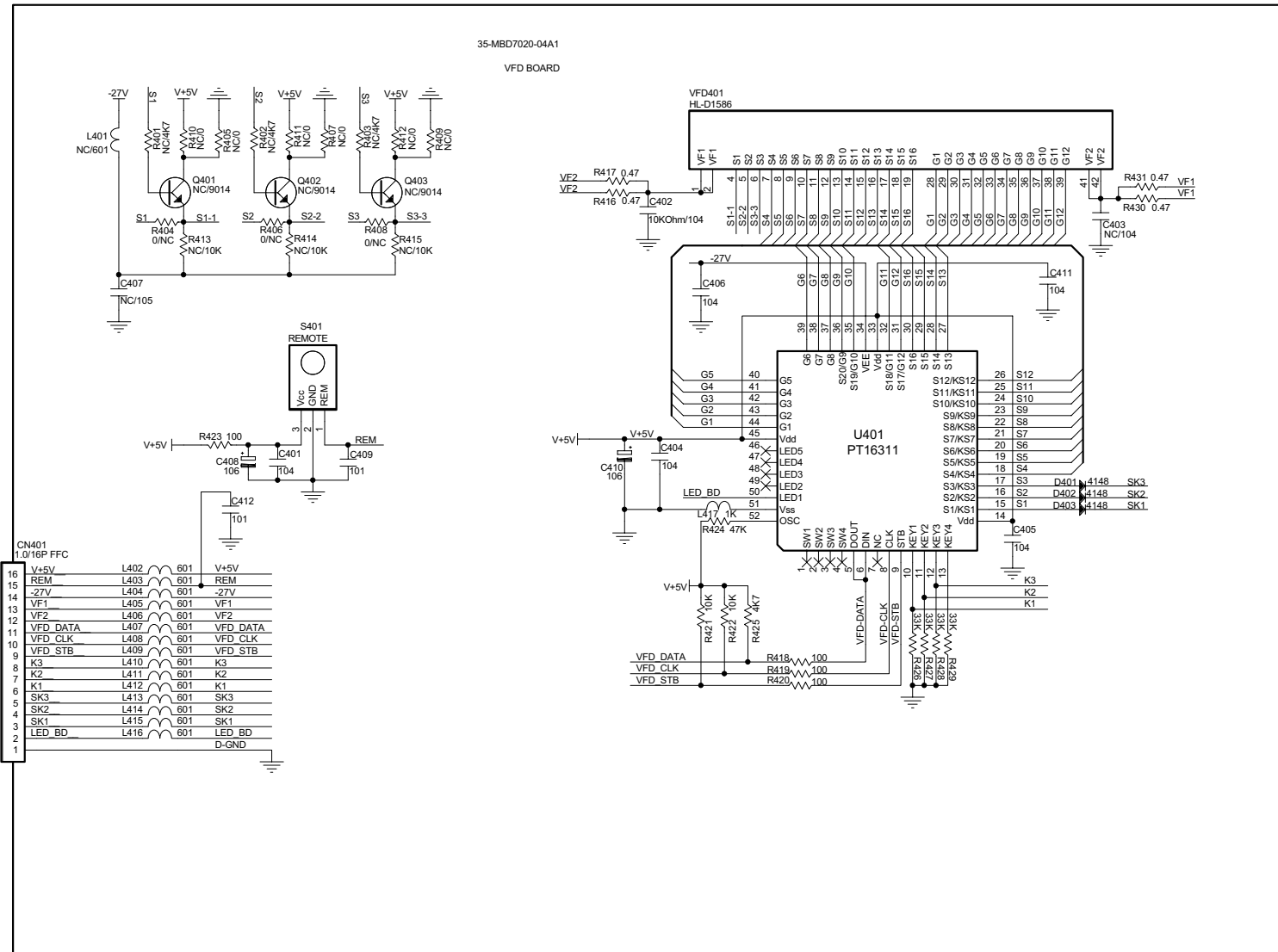

Display Board -- Layout Diagram

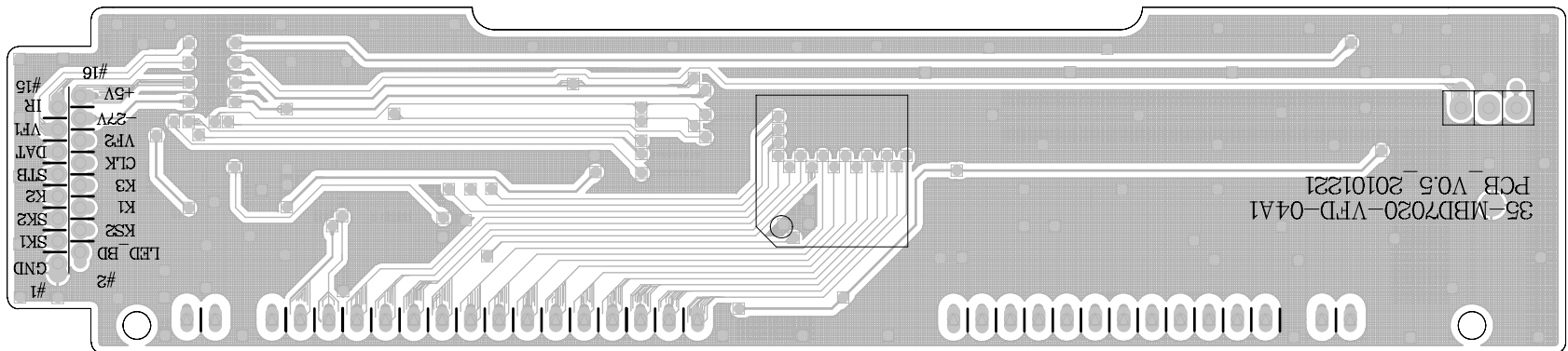
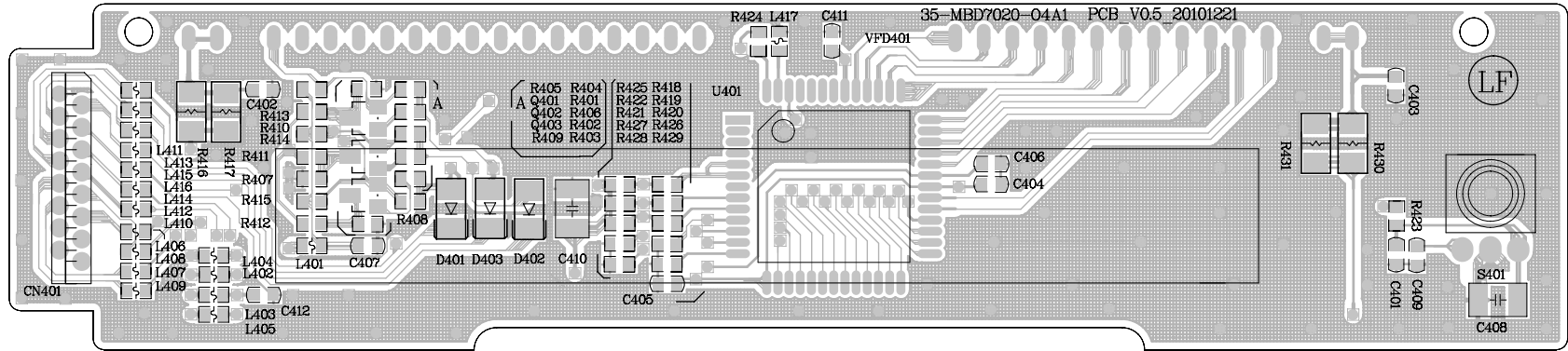

Headphone & MP3 Link and USB、LED BOARD -- Circuit and Layout Diagram

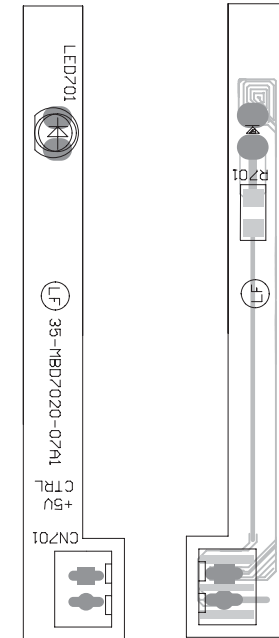
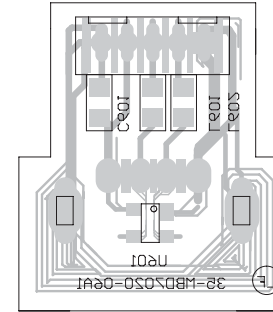
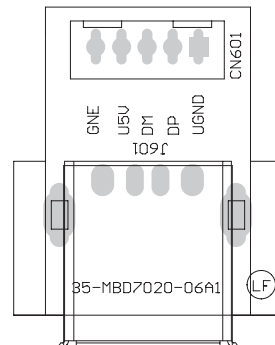
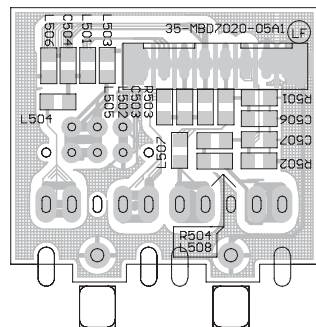
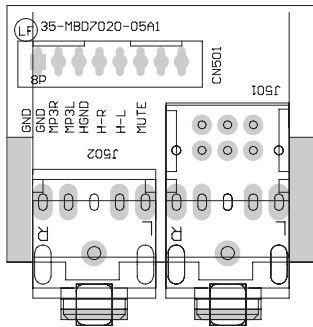
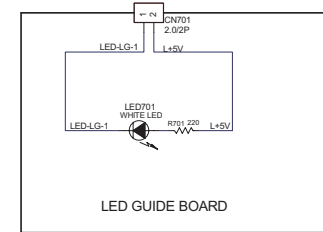
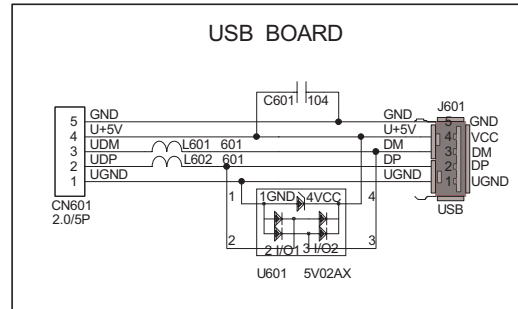
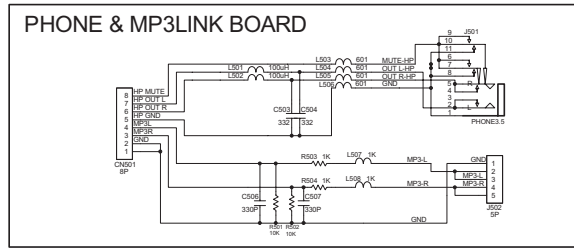

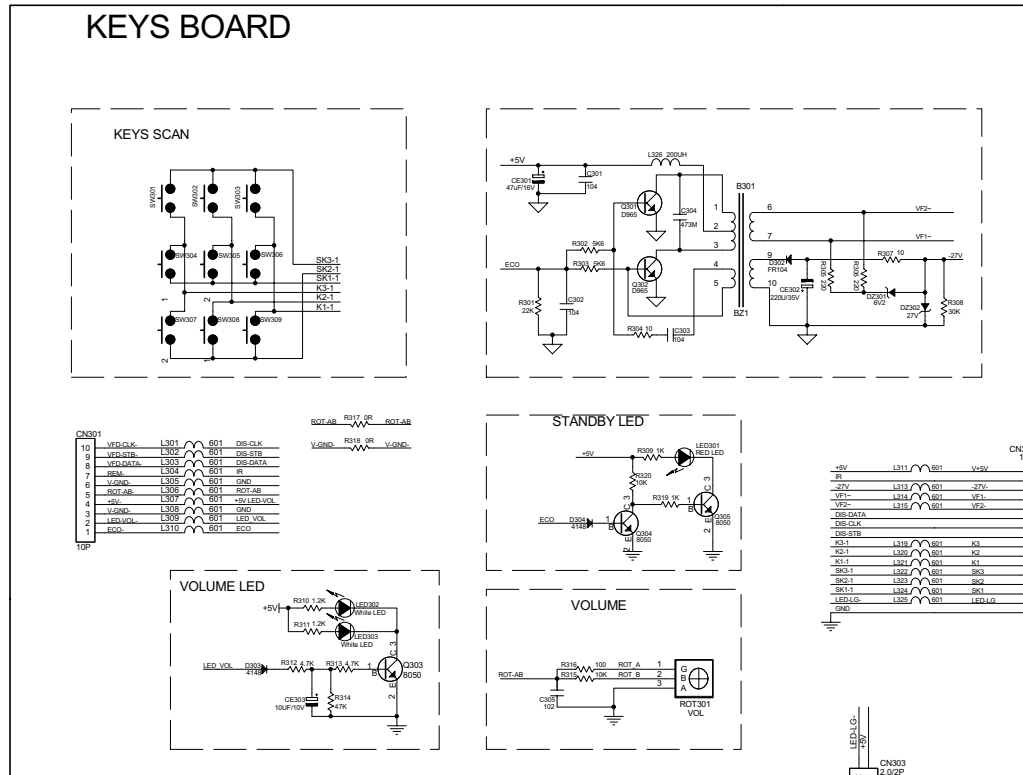

Power Board -- Circuit Diagram 1

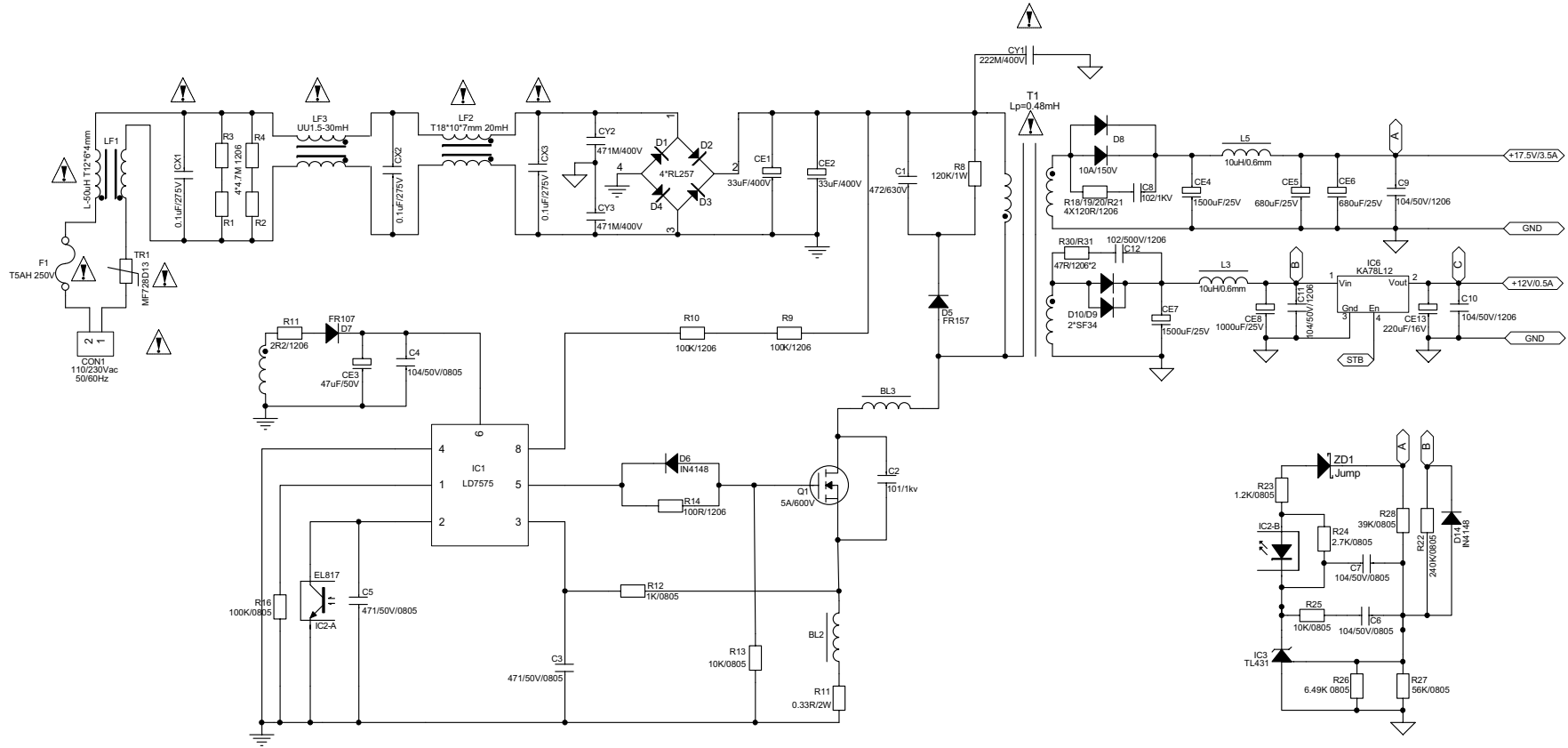

Power Board -- Circuit Diagram 2

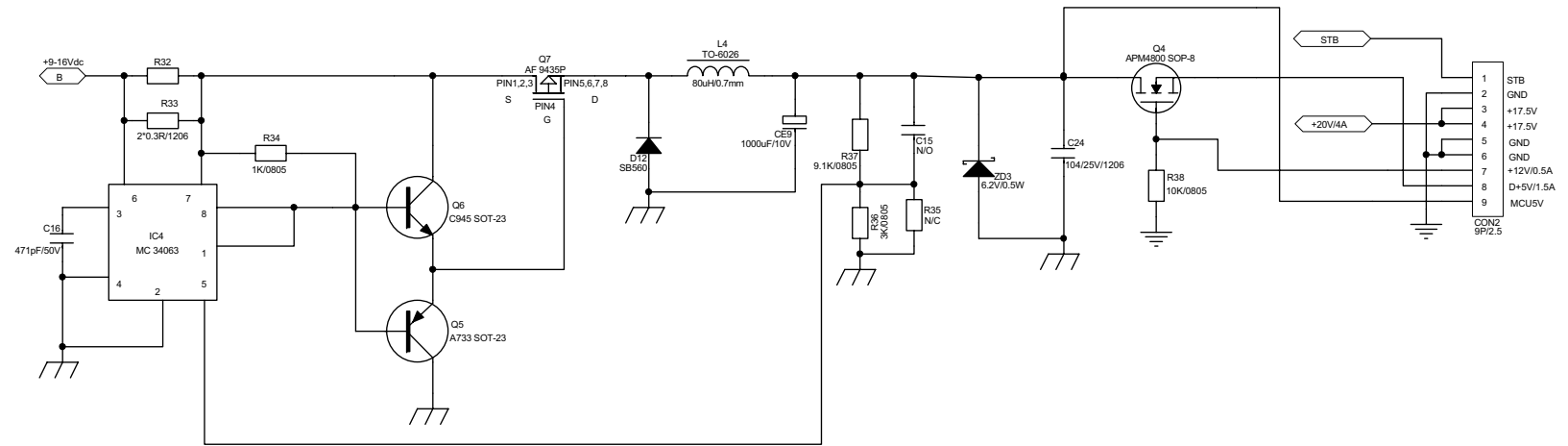

Power Board -- Layout Diagram

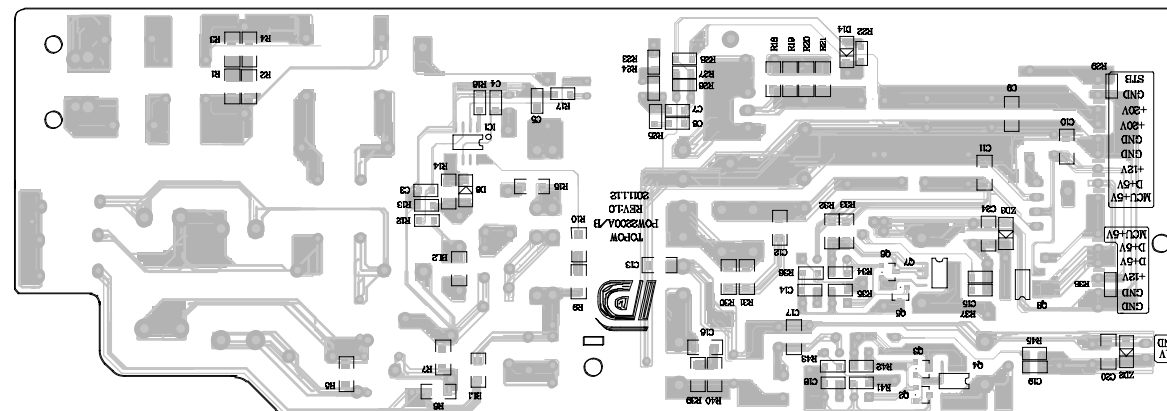
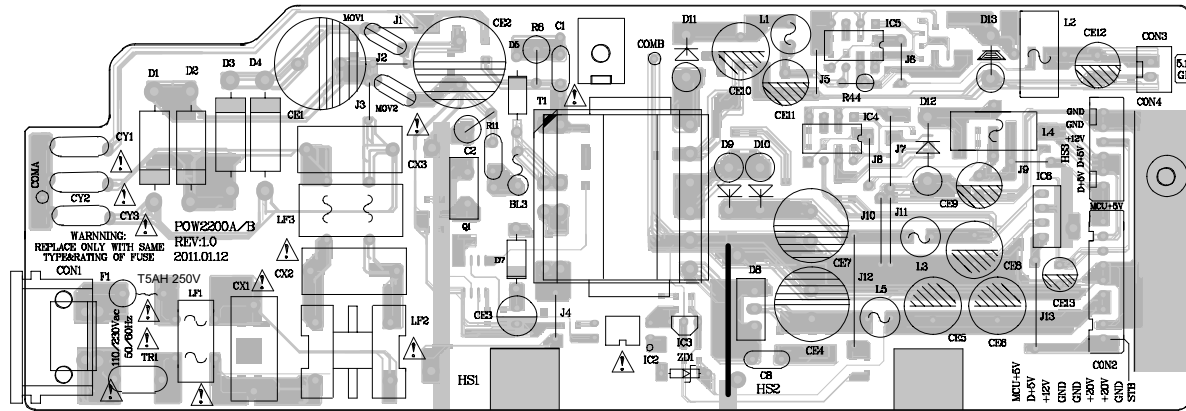

Decoder Board -- Circuit Diagram 1

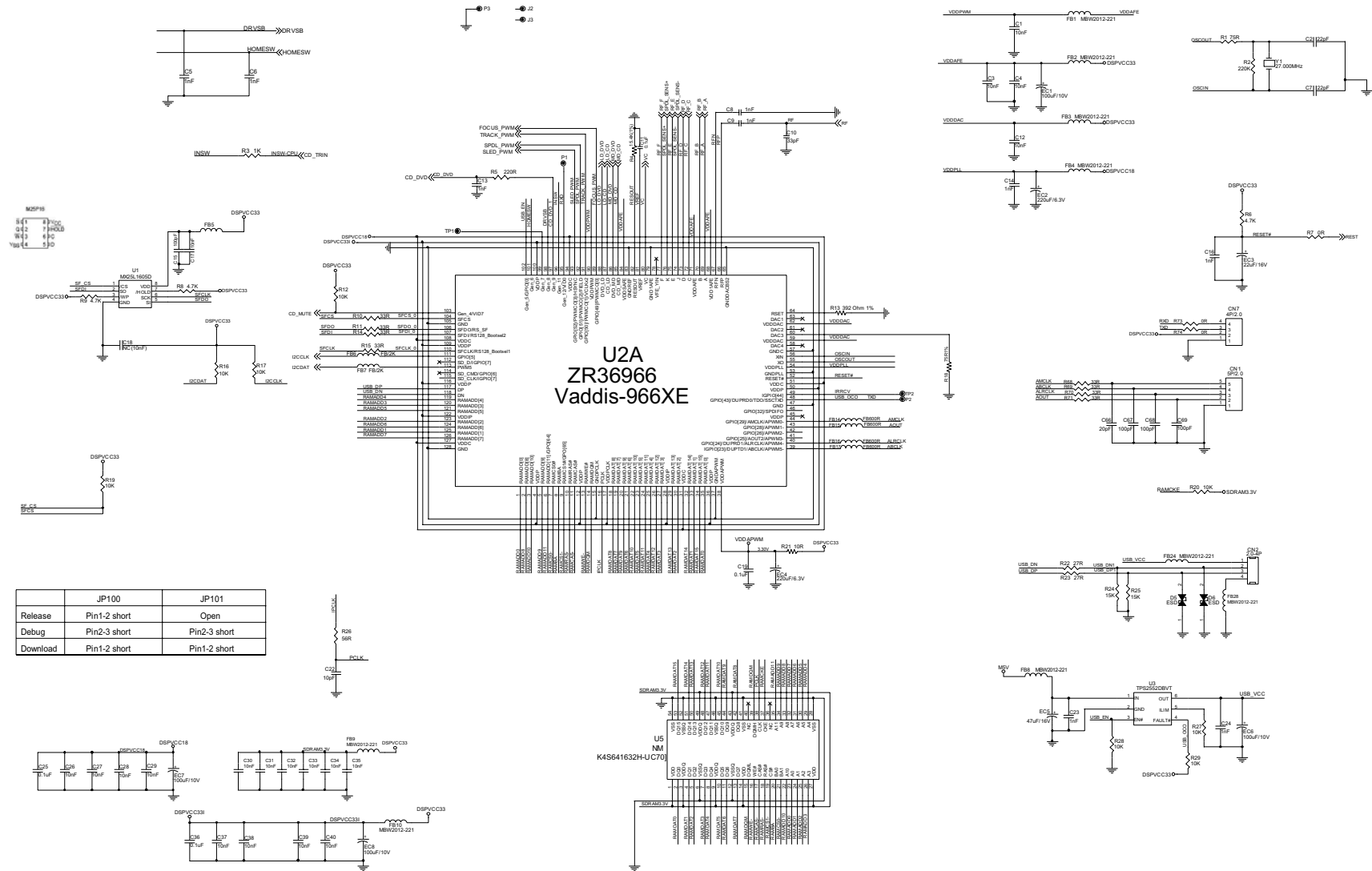

Decoder Board -- Circuit Diagram 2

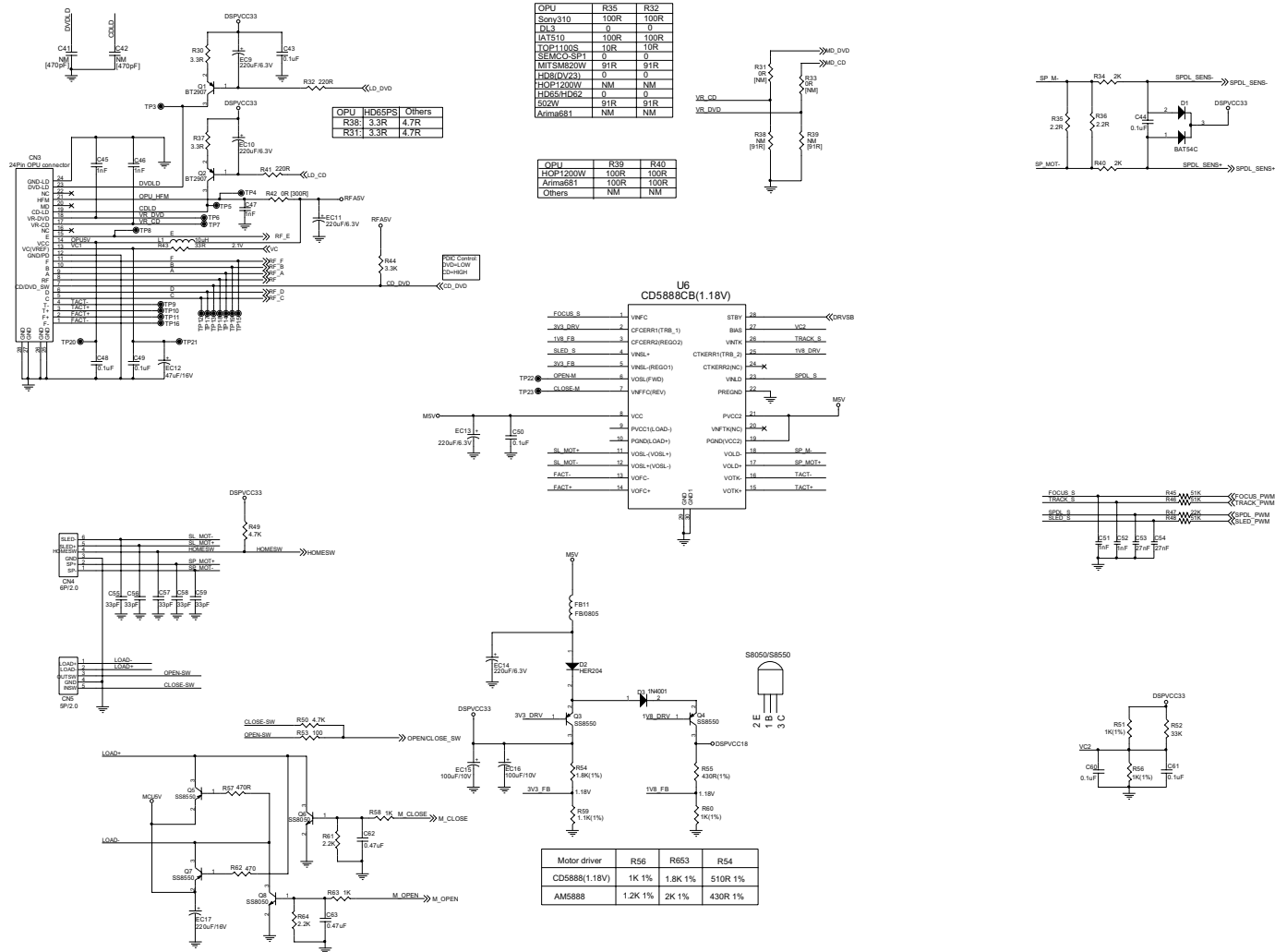

Decoder Board -- Circuit Diagram 3

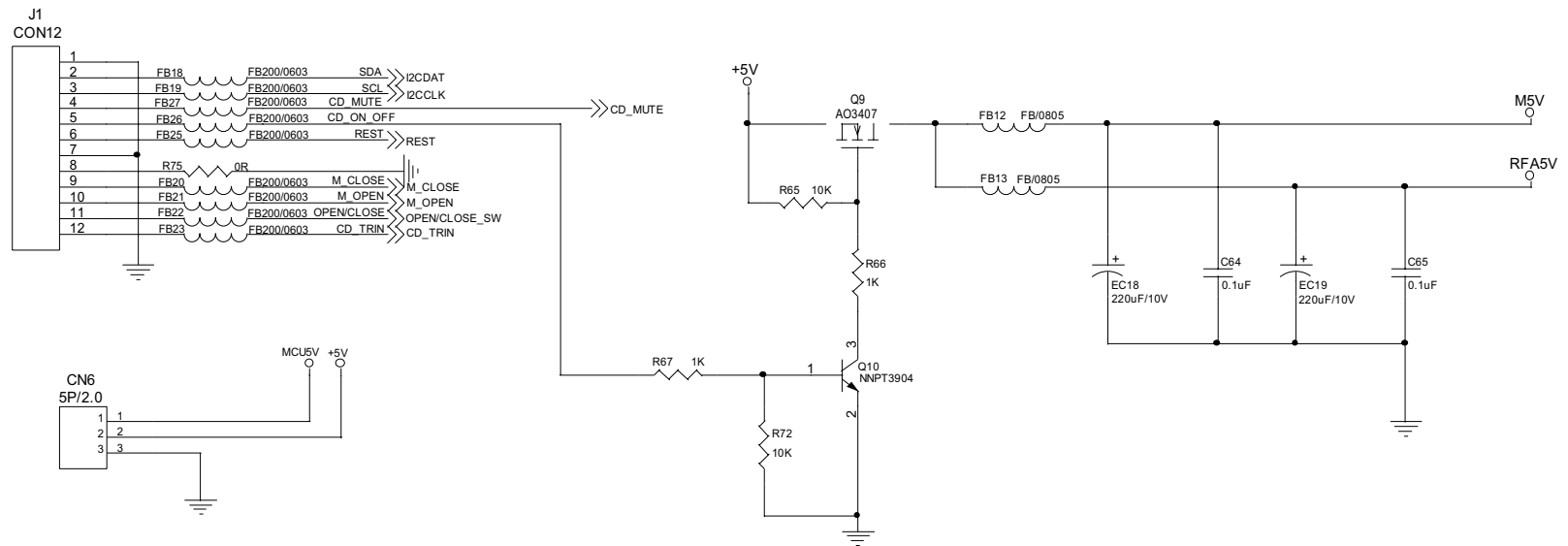

Decoder Board -- Layout Diagram

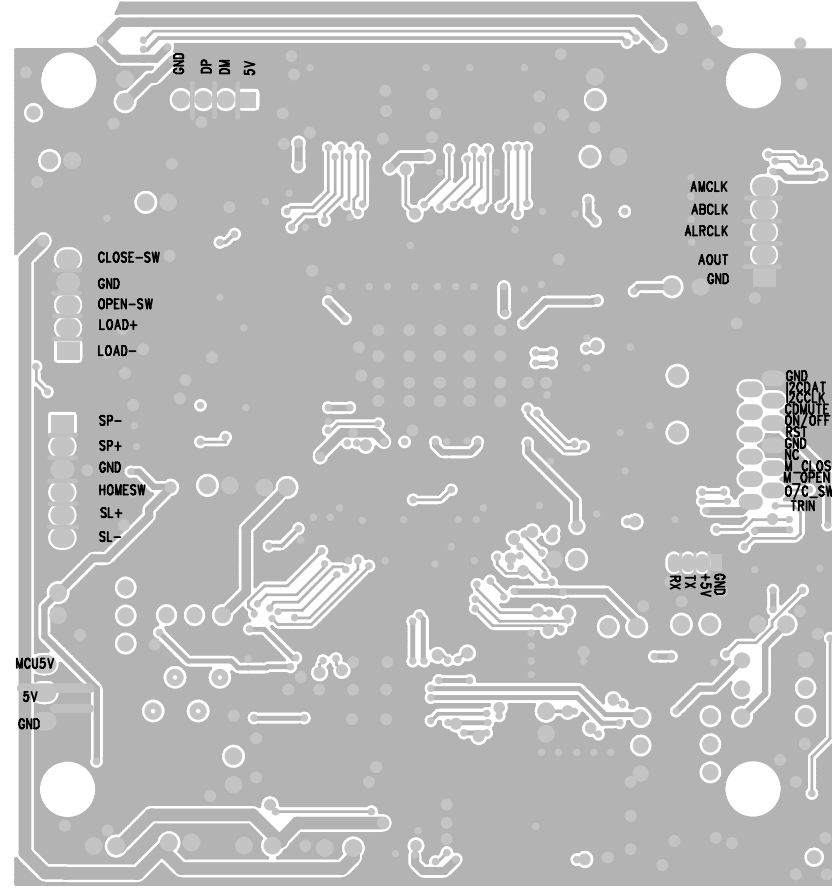
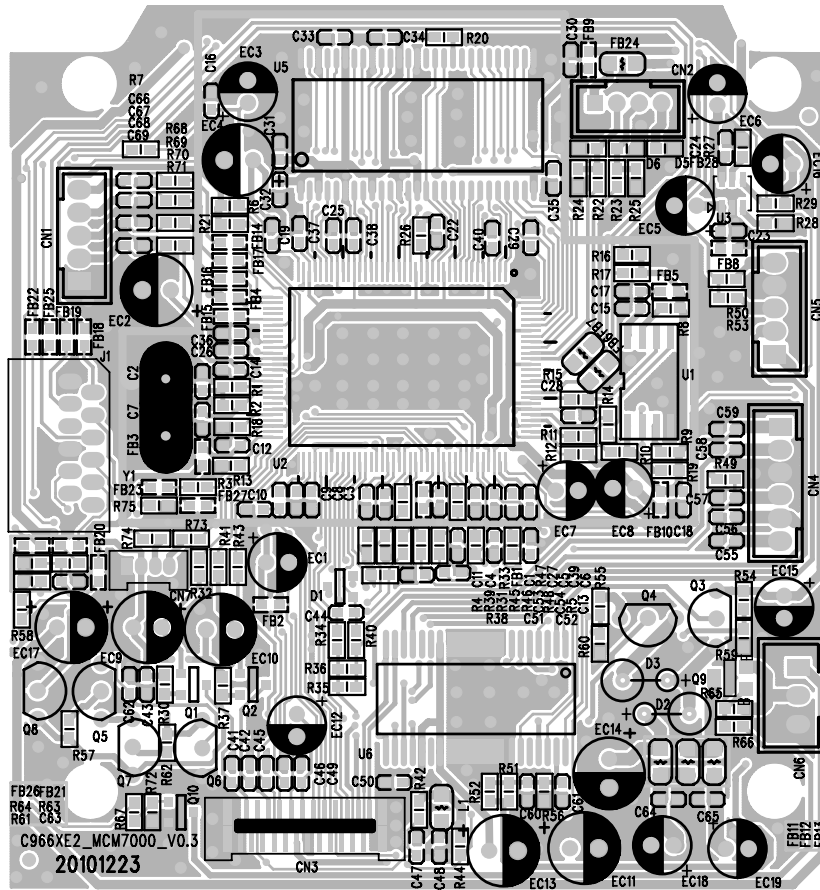

Exploded View

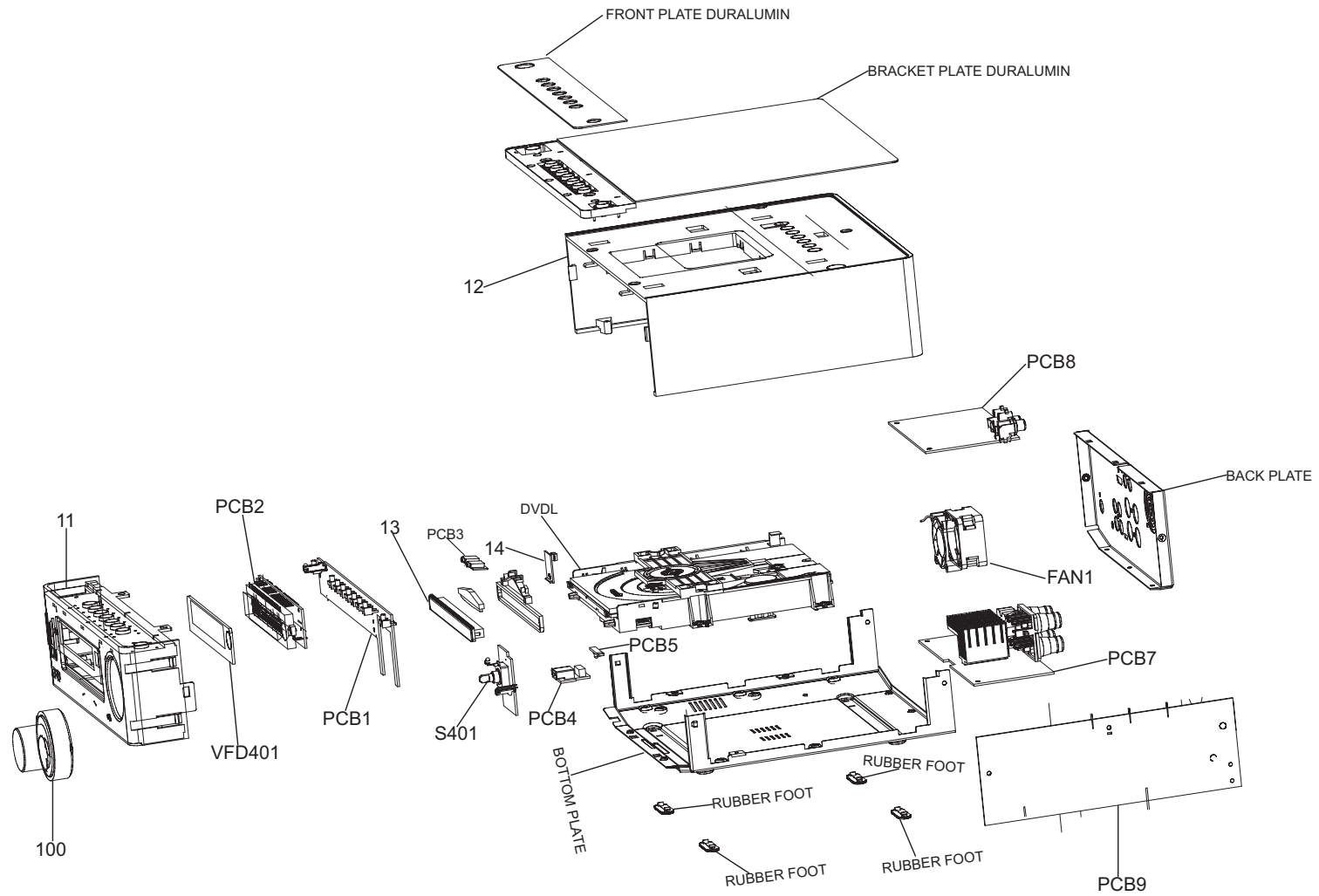

Revision List

Revision List

Version 1.0
* Initial Release